



Midwest Reliability Organization Model Building Manual

December 2009

Midwest Reliability Organization

2774 Cleveland Ave N
Roseville, MN 55113
651-855-1760

Prepared by: Laura Elsenpeter, MRO Staff

Approved by MRO Model Building Subcommittee December 4, 2009

Table of Contents

1. General Information	3
1.1. Introduction.....	3
1.2. Purpose.....	3
1.3. Mission Statement.....	3
1.4. Scope of Activities.....	3
1.5. Membership.....	4
1.6. Meetings.....	4
2. Duties of the Model Building Subcommittee	6
2.1. Duties of the Chairman.....	6
2.2. Duties of the Secretary.....	6
2.3. Duties of the Members.....	6
2.4. Duties of the Data Representatives.....	7
3. Power Flow Data Submittal Process	8
3.1. Schedule.....	8
3.2. Data Request and Submittal.....	8
3.3. Data Checks Following Upload to Model Building Database.....	8
3.4. Model Building System Database.....	8
3.5. Preliminary Model Checks.....	9
3.6. Model Releases and Updates to the Final Models.....	9
3.7. Data Representative Training.....	10
4. Power Flow Case Development	11
4.1. Model Detail.....	11
4.2. Swing Bus.....	11
4.3. Set of Models.....	12
4.4. Transaction Workbooks.....	14
4.5. Transaction Crosscheck.....	14
4.6. Inter-regional Schedules.....	16
4.7. Inter-regional Tie Line Coordination.....	16
4.8. Shared Generators.....	16
4.9. Operating Reserves.....	16
4.10. Transmission System Reporting Responsibility.....	16
4.11. Future Generation and Transmission Facilities.....	17
4.12. Planned.....	18
4.13. Proposed.....	18
4.14. Exploratory.....	19
4.15. Power Flow Model Development Guideline.....	19
5. Dynamic Model Development	31
5.1. Model Definition.....	31
5.2. Data Submitter Model Development Guidelines.....	31
5.3. Guidelines for Wind Turbine Generators (WTG).....	32
5.4. Steps for Receiving Dynamic Data.....	32
5.5. Dynamic Model Development.....	32
5.6. Dynamic Data/Model Screening During Model Development.....	33
5.7. Final Dynamics Deliverables.....	33
6. Preparation and Transmittal of Member Data	36

- 7. Model Documentation36**
 - 7.1. Power Flow Model Documentation36
 - 7.2. Dynamic Documentation36
 - 7.3. Short Circuit Documentation36
- 8. MBS Compliance Program38**
 - 8.1. Compliance Timing Issues.....38
 - 8.2. Compliance Quality Issues.....38
 - 8.3. Non-Compliance and Levels of Non-Compliance.....39
- Appendix A - Systems Codes for Power Flow Data.....40**
- Appendix B - Typical Parameters.....42**
- Appendix C - Wind Turbine Generator (WTG) Models44**

1. General Information

1.1. Introduction

The MRO Model Building Subcommittee (MBS) reports to the MRO Reliability Assessment Committee (RAC). The RAC will appoint the MBS voting members and ratify all other personnel assigned to the MBS. The Chairman and Vice Chairman of the MBS will be appointed by the Chairman of the RAC and a MRO staff member will serve as the Secretary.

1.2. Purpose

To promote the reliability of the Bulk Electric System¹ (BES) in the MRO Region and to contribute toward the reliability of the Eastern Interconnection, the MBS is responsible for annually developing a library of solved power flow models, associated dynamic simulation models and a short circuit model (requirement reviewed annually) of the MRO Corporate Region. The models are to meet Eastern Interconnection Reliability Assessment Group (ERAG) Multiregional Modeling Working Group (MMWG) model building obligations, for use by the Region and its member systems, as well as for use in development of inter-regional models. The models will satisfy the approved NERC Standards outlined in the annual data request.

The MBS is responsible to monitor the collection and processing of electric system data to support MRO, ERAG, Energy Information Administration (EIA), and any other data publications as necessary to help eliminate duplication and inefficiency in data reporting processes while improving overall data accuracy and consistency.

1.3. Mission Statement

The mission of the MBS is to provide a consistent and accurate series of operating and planning power flow, stability and short circuit models in a timely manner. The MBS shall act as project manager responsible for project direction, priority, budget and deadlines. The MBS will continue to ensure that the basic model requirements of MMWG and the MRO Region are satisfied.

1.4. Scope of Activities

In carrying out the above purpose, the MBS will:

- Oversee the development of a library of solved (converged) steady-state system models.
- Oversee the development of compatible dynamic system models.
- Oversee the development of a short circuit model compatible with the operating (year 1) steady-state system model when included in a model series.
- Oversee the collection of Under Frequency Load Shedding (UFLS) and Under Voltage Load Shedding (UVLS) data.
- Oversee the collection of Wind Generator Data supplementing model data.
- Oversee the collection of Generator Reactive Capability data.
- Prepare documentation of each model series.

¹As defined in the NERC Glossary of Terms <http://www.nerc.com/page.php?cid=2|247|108>

- Oversee the benchmarking of the models, and include the results of this benchmarking in the documentation of the model series.
- Maintain the *MRO Model Building Manual*.

1.5. Membership

The MBS membership shall consist of geographical representation including Regional Transmission Committee and MISO liaison members, and other representatives as deemed appropriate by the RAC. Voting Members of the MBS must be from a company who is currently a Member of the MRO.

Voting Members (a minimum of one, no more than two from each area):

- Dakotas
- Minnesota
- Nebraska
- Iowa
- Canada (Manitoba and Saskatchewan)
- Wisconsin/Michigan

The members representing each area have the responsibility to coordinate necessary information within their geographical boundary.

Non-Voting Members

- MAPP Regional Transmission Committee Liaison
- MISO Liaison
- Midwest Reliability Organization Staff

1.6. Meetings

The MBS shall meet as required to make decisions related to the annual MRO model series, which takes into account the North American Electric Reliability Corporation (NERC) and Federal Energy Regulatory Commission (FERC) requirements. The following are typical agenda items of MBS meetings.

1. The annual data request for the upcoming model series is reviewed and modified as appropriate.
2. The schedule for developing the upcoming model series is reviewed and modified as appropriate.
3. Review and approval of the list of models
4. Review and approval of the PSS/E version.
5. The *MRO Model Building Manual* is reviewed in detail, and revised as required.
6. New NERC, FERC and ERAG requirements for models are discussed and implemented as required.
7. Developments and enhancements to the tools (e.g., database or other software) used for model building are discussed and prioritized. The tools must be compatible with the version of PSS/E targeted for a given release.
8. The MRO representative on the ERAG MMWG reports on the working group's activities.

9. Representatives from other MRO Subcommittees or Working Groups which may have implications on the model building process report on the group's activities.

2. Duties of the Model Building Subcommittee

2.1. Duties of the Chairman

1. Work with the MBS Secretary and MBS members to solve problems that may arise in the development of the annual MRO model series.
2. Work with the MBS Secretary in preparing meeting agendas and supporting documents.
3. Lead MBS meetings.
4. Provide a written report to the RAC including:
 - a. The agreed upon list of models to be provided by the Contractor, the PSS/E version and the compiler to be used for the upcoming model series.
 - b. A status report of the current MBS actions as related to its scope of activities.

2.2. Duties of the Secretary

1. The Secretary position will be held by MRO Staff.
2. Responsible for coordinating with contractors.
3. Prepare time schedules for each model building function for approval by the MBS.
4. Participate with the MBS in preparing the annual model series data request, and send the data request to each company data representative and compliance contact.
5. Report to the MBS a list of non-compliant companies specifying which compliance criterion was violated.
6. Prepare progress reports at regular intervals during periods of significant model building activities, as requested by the MBS.
7. Update the MBS to the actions of the Regional Entities and MMWG.
8. Contact the appropriate data representative should any problems develop with their data set or to advise them if their data requires special processing.
9. Work with the MBS Chairman in preparing meeting agendas, supporting documents and meeting minutes.
10. Coordinate requested changes to the final models through the data representative and MBS who must approve the changes. The MBS Secretary should post these changes on the MRO FTP site, and notify model users of the change through a general broadcast message.

2.3. Duties of the Members

1. Coordinate inter-regional interchange transaction schedules and inter-regional tie lines for each case. The MBS will coordinate any changes to the tie lines with the model building contractor staff and the data representative within the MRO who owns or partially owns the tie line.
2. Assist the model building contractor to solve non-convergent base cases.
3. Review the solved MRO power flow cases to verify an accurate system representation. The cause of any system problem associated with creating the

cases should be determined with the objective of preventing similar problems in the future.

4. Approve and validate any changes submitted after the final models are released. Coordinate with the MBS Secretary the posting of a correction and appropriately documenting the correction in a text file specified for that purpose.
5. Annually review the power flow base case model requirements for ERAG and the MRO Region and recommend the appropriate models to be developed, and the PSS/E version to use for the models.
6. Review the MRO model series development schedule and make any necessary adjustments
7. Work with the data representatives and the model building contractor to coordinate and assure the timely submission of member system data.
8. Keep abreast of the modeling requirements of member systems and adopt or develop improved modeling and data handling techniques as required.
9. Keep abreast of state-of-the-art techniques and evaluate alternative methods for developing the power flow library and associated dynamics model.
10. Act as coordinators between their geographical region and the model building contractor. Be responsible for a final high level review of their region before the models are released, and for ensuring that municipal load data for their region is included in the models.

2.4. Duties of the Data Representatives

The data representative is an individual from each Registered Entity in the MRO footprint that will be responsible for submitting/providing data to the MRO in accordance with NERC Standards or as requested by the ERAG MMWG.

The data representatives are responsible for submitting the following data in accordance with the schedule provided in the annual data request:

- Power Flow/Dynamics
- Wind Generator Data (Supplementing Model Data)
- Machine Reactive Capability Data
- Short Circuit²
- UFLS³ and UVLS⁴

Model data requirements and guidelines are further described later in this manual and in the annual data request. In addition to the initial data submittal, the data representatives are also responsible for reviewing preliminary model releases and providing corrections as needed.

Each data representative should prepare data consistent with its most recent official system forecasts in all data submitted to MRO including EIA-411 information. The models should represent a realistic operation of the MRO system.

² If Required

³ MRO will collect UFLS data separate from the annual data request once final models are posted

⁴ Currently, the MRO does not have UVLS equipment in the region

3. Power Flow Data Submittal Process

3.1. Schedule

The data representatives should be familiar with the model building schedule and milestones well in advance of all deadlines. This should avoid problems with the timing of data preparation, submittal and reviews.

The model building schedule is posted on the MRO website and will be updated as necessary.

http://www.midwestreliability.org/REL_model_building_schedule.html

3.2. Data Request and Submittal

The data request for the upcoming model series is distributed to each Registered Entity's data representative and Compliance Contact by the MBS Secretary. The model series data is forwarded by the data representatives to the model building contractor no later than the due date. All power flow data should be submitted in accordance with the guidelines described in the MRO Model Building Manual and any additional guidelines described in the annual model series data request.

3.3. Data Checks Following Upload to Model Building Database

After the data representatives submit and accept their data into the model building database they should do the following:

- view the data submission from within the database application,
- export the input files to ensure the data was read in correctly
- build a test case using the data submission to evaluate integrity of the data in PSS/E

When provided, the data representative should use any data auditing programs provided with the model building software package to further troubleshoot their data.

3.4. Model Building System Database

Once all data has been received from the members for a specific case, the data will be merged into a MRO model. The following parameters will be used:

1. The MBS database will utilize the MRO tie line table, developed by the ERAG MMWG, for all inter-regional tie lines. Issues may arise due to duplicate or improperly named buses when inserting these tie lines. If this is the case, data representatives will be notified of any problems.
2. A desired net interchange value will be calculated for each PSS/E area based on the transaction data submitted by each company. The models will be solved with area interchange enabled using "Tie lines and loads".
3. The MRO power flow cases being solved from a flat start using a Fixed Slope Decoupled Newton Raphson (PSSTME actively FDNS) solution followed by a Full Newton solution (PSSTME actively FNSL) must meet the following parameters :
 - a. Solve in less than 20 iterations with acceleration of 1.0.

- b. Employ a 0.1 MW/MVAR per bus mismatch tolerance.
 - c. Enforce area interchange with the “Tie lines and Loads” option.
 - d. Apply Generator VAR limits immediately (it may be beneficial to apply VAR limits at the 2 iteration when using a flat start).
 - e. Enable:
 - i. Tap adjustment set to Stepping
 - ii. Switched shunt adjustment set to Enable All
 - iii. Select Adjust phase shift
 - iv. Select Adjust DC taps
4. Successfully converged MRO cases will be named with the following convention:

MRO-[Series-Year]-[Case(YYYYseason)]-[Release Type].sav

For Example: MRO-SER07-2008SUPK-FINAL(pre-dyn).sav

3.5. Preliminary Model Checks

During the update to the preliminary models, all voltage and thermal overloaded violations on the BES must be investigated in the base case models.

Default acceptable bus voltage levels shall be between 0.95 P.U. and 1.05 P.U. of the nominal voltage base of the system, unless an exception has been provided by the Registered Entity. Default acceptable branch loading level is less than or equal to 100% of Rate A.

The final models may show voltage and branch loading violations on the BES; however, these occurrences should be investigated and highlighted in the model documentation.

3.6. Model Releases and Updates to the Final Models

The MBS encourages data representatives to submit significant changes after the final models are posted on the MRO FTP site; however, these changes will not be incorporated into the model series. Rather, these changes will be made available to the model users by posting them on the same FTP site in an IDEV file with a description of the model changes shown in a README.DOC file. The MBS has adopted the following practices regarding the release of models and posting of model changes.

1. The initial preliminary models (Pass-1, Pass-2, etc.) should be released for model verification to the data representatives and MBS members only. They should not be released to other model users.
2. Ensure minimal subsequent releases of the models, for model verification, to the data representatives.
3. To meet project timetables, near complete power flow models could be released (based on MBS approval) to the model users. Included would be brief documentation of the status of the models, work outstanding to finalize the models, and (if appropriate) changes since the last released version of the

models. This would only include models passing an appropriate level of acceptance verification.

4. It is desired to have three releases per MRO model series, which are as follows: Pass-1, Pass-2, and Final after Dynamics.
5. Changes received after the FINAL model release will be made available to the model users, subject to MBS approval, in the form of documentation and associated update files. In order to provide model building contractor staff with a cutoff for model building of a particular series, these *late* changes should not be applied to the posted FINAL models.

The model users will be advised, by the MBS Secretary broadcasting a message, that a model change has been posted. Each model user may decide whether or not to apply these changes to their study models.

3.7. Data Representative Training

The model building contractor and the MBS Secretary will conduct data representative training as needed. The method of model data submittal is through the Siemens PTI Model on Demand (MOD) database accessible through the internet. Whenever there are major changes to the model data requirements, or when PTI changes the format of their model data files, corresponding changes are required in the database. If determined as a requirement by the MBS, data representative MOD training will be conducted prior to issuing the annual data request.

4. Power Flow Case Development

In support of the following, you may also refer to the ERAG MMWG Manual – Appendix V: Power Flow Modeling Guidelines; the latest version can be downloaded from <http://www.erag.info/MMWG.aspx>.

4.1. Model Detail

Of paramount importance is the detail in which the various systems are represented. The detail included in each system representation should be adequate for all MRO regional and inter-regional study activities but not necessarily as detailed as required for individual member company studies. This means that each system representation should include sufficient detail to ensure that power transfers and contingencies can be realistically simulated.

It is expected that the entity(ies) conducting a study may find it necessary to expand and/or update the representation of system conditions and facilities in the area of particular concern, but substantial updating of other systems at the time of use should not be required. It is also expected that a regional study group will perform some fine tuning of the study area just prior to the initiation of a particular study to incorporate changes in system expansion plans, which may have occurred since the data for the MBS cases were assembled.

To satisfy the requirements of the individual members, as well as the various study groups, the library of base cases will be updated annually or as required to ensure that each case contains the best available data for the time period modeled.

The series of cases shall be an accurate and consistent representation of all major generation, load, and transmission facilities in the MRO region from which specific regional and sub-regional study cases may be developed.

4.2. Swing Bus

TVA's Brown's Ferry generator is the swing machine in the Eastern Interconnection for all MBS cases. The swing machine has its voltage fixed in magnitude and phase. Other swing machines are designated in all other synchronous or non-synchronous areas (i.e., systems on the opposite end of a DC line). Each must be the regulating generator (slack bus) of the synchronous subsystem in which it is located.

4.3. Set of Models

The MBS develops a library of power flow cases that satisfy the requirements of the NERC Reliability Standards, ERAG MMWG, and the MRO region. The ERAG MMWG requires the preparation of approximately thirteen power flow models as shown in the table below. There are typically about three additional models needed by MRO member companies.

Model Year	Light Load	Spring Peak	Summer Peak	Fall Peak	Winter Peak	Summer Shoulder
1	MMWG	MMWG	MMWG	MMWG	MMWG	MMWG
2		MMWG	MMWG		MMWG	
6	MMWG		MMWG		MMWG	MRO
11			MMWG		MRO	MRO

Note: model year one is defined as the year following the model series year. For example model year one in the 2008 series would be 2009.

Summer Shoulder: The north-central MRO region (consisting of Manitoba, the Dakotas, and Minnesota) requires summer off-peak (summer shoulder peak) cases for conducting stability analysis to establish System Operating Limits and for transmission planning. Key flowgate transfer capability is studied using early year (for System Operating Limits) and out-year (for transmission planning) summer off-peak cases. Summer shoulder peak (70% peak) cases are used because the north-central MRO region experiences high interchange (above firm levels) under these load conditions. With the winter peaking regions of MRO, spring and fall peak cases are near summer peak load levels and therefore do not provide the appropriate base case load conditions suitable for development of the required study cases.

Summer Peak Load - is defined as the summer peak demand expected to be served, reflecting load reduction for peak shaving. The load should be consistent with the NERC EIA-411 data. To properly coordinate with the ERAG Inter-regional power flow model development, the load data submitted should not be reduced for wholesale application of controllable demand-side management, curtailment of interruptible loads, or for emergency procedures such as voltage reductions and the anticipated effects of public appeals. The effects of uncontrolled demand-side management (peak shaving) should be reflected in the load of summer peak cases. Topological modeling changes shall be incorporated into the model if they are effective on or before July 15th. Summer interchange schedules should reflect transactions expected to be in place on July 15th. For purposes of validating schedules with the OASIS database, any schedules active in OASIS from June 1 through August 31 will be used for validating OASIS ID's. Some summer interchange schedules may not be in the OASIS system at the time the MRO series models are developed. Planned summer maintenance of generation and transmission should be reflected in the operating year case.

Winter Peak Load - is defined as the winter peak demand expected to be served, reflecting load reduction for peak shaving. The load should be consistent with the

NERC EIA-411 data. To properly coordinate with the ERAG Inter-regional power flow model development, the load data submitted should not be reduced for wholesale application of controllable demand-side management, curtailment of interruptible loads, or for emergency procedures such as voltage reductions and the anticipated effects of public appeals. The effects of uncontrolled demand-side management (peak shaving) should be reflected in the load of winter peak cases. Topological modeling changes shall be incorporated into the model if they are effective on or before January 15th. Winter interchange schedules should reflect transactions expected to be in place on January 15th. For purposes of validating schedules with the OASIS database, any schedules active in OASIS from December 1 through February 28 will be used for validating OASIS ID's. Some winter interchange schedules may not be in the OASIS system at the time the MRO series models are developed. Planned winter maintenance of generation and transmission should be reflected in the operating year case.

Spring Peak Load - is defined as typical spring peak load conditions. Topological modeling changes shall be incorporated into the model if they are effective on or before April 15th. Pumped storage hydro units should be generally modeled on line, but not necessarily at full generating capacity (generally not pumping). Dispatchable hydro units should generally be modeled on line, but not necessarily at maximum generation, and run-of-river hydro should be modeled on line. Generation dispatch and interchange schedules should commensurate with the experience of the Regions during such load periods, not just including firm transactions. Planned spring maintenance of generation and transmission should be reflected in this case. Summer or appropriate equipment ratings should be used. Spring interchange schedules should reflect transactions expected to be in place on April 15th. For purposes of validating schedules with the OASIS database, any schedules active in OASIS from March 1 through May 31 will be used for validating OASIS ID's. Some spring interchange schedules may not be in the OASIS system at the time the MRO series models are developed.

Fall Peak Load - is defined as typical fall peak load conditions. Topological modeling changes shall be incorporated into the model if they are effective on or before October 15th. Pumped storage hydro units should be generally modeled on line, but not necessarily at full generating capacity (generally not pumping). Dispatchable hydro units should generally be modeled on line, but not necessarily at maximum generation, and run-of-river hydro should be modeled on line. Generation dispatch and interchange schedules should commensurate with the experience of the Regions during such load periods, not just including firm transactions. Planned fall maintenance of generation and transmission should be reflected in this case. Summer or appropriate equipment ratings should be used. Fall interchange schedules should reflect transactions expected to be in place on October 15th. For purposes of validating schedules with the OASIS database, any schedules active in OASIS from September 1 through November 30 will be used for validating OASIS ID's. Some fall interchange schedules may not be in the OASIS system at the time the MRO series models are developed.

Light Load - is defined as a typical early morning load level, modeling at or near minimum load conditions. Topological modeling changes shall be incorporated into the model if they are effective on or before April 1st. Pumped storage hydro units should either be modeled off line or in the pumping mode, with appropriate pumping Interchange schedules in place. Dispatchable hydro units should generally be modeled off line, with run-of-river hydro on line. Generation dispatch and interchange schedules should commensurate with the experience of the Regions during such load periods, not just reflecting contractual firm transactions. Planned spring maintenance of generation and transmission should be reflected in this case. Summer or appropriate equipment ratings should be used. For purposes of validating schedules with the OASIS database, any schedules active in OASIS from March 1 through May 31 will be used for validating OASIS ID's. Some spring light load interchange schedules may not be in the OASIS system at the time the MRO series models are developed.

Shoulder Peak Load (summer) - is defined in the MRO model series as 70% of summer peak load conditions. The ERAG MMWG Shoulder Peak Load is defined as 70% to 80% of summer peak load conditions. Pumped storage hydro units should be modeled on line, but not at full generating capacity (generally not pumping). Dispatchable hydro units should generally be modeled on line (probably not at maximum generation), with run-of-river hydro on line. Generation dispatch and interchange schedules should commensurate with the experience of the Regions during such load periods, not just reflecting contractual firm transactions. Summer or appropriate seasonal equipment ratings should be used. For purposes of validating schedules with the OASIS database, any schedules active in OASIS from May 1 through October 31 will be used for validating OASIS ID's. Some summer interchange schedules may not be in the OASIS system at the time the MRO series models are developed.

4.4. Transaction Workbooks

Company workbooks will be provided with the annual data request for each company to submit generation, load, loss, and transaction data. You will use this workbook to balance your company's load and resources. Losses must be a reasonable, positive number, and based on the previous year's data submittal. The data collected in these spreadsheets will be compiled by MRO staff to generate desired net interchange amounts for each of the PSS/E areas in the MRO footprint. Refer to the workbook for further instructions and definitions.

All MRO to MRO transactions must net to zero, and therefore, must be coordinated among the Registered Entities. If a data representative wishes to model a transaction with an entity which is not registered in the MRO footprint, that transaction will have to be shown as a transaction with an outside region (i.e., Southwest Power Pool (SPP) or ReliabilityFirst Corporation (RFC)).

4.5. Transaction Crosscheck

All transactions included in the MRO model series must be coordinated between the two Entities involved in the transaction. Both Entities participating in the transaction must enter the same amount and same type of the transaction and the same OASIS ID if one exists. A list taken from the OASIS database, showing the valid transactions including various OASIS ID numbers for a given company for each of the series models is available. Any OASIS ID on this list can then be used in the transaction. Following the initial workbook data submittal, MRO staff will notify any data representatives that have mismatched transactions. The data representatives for those two Entities will be responsible for coordinating the correct transaction and will submit a revised workbook according to the model building schedule.

4.6. Inter-regional Schedules

It is RFCs policy that any inter-regional schedules are required to have corresponding OASIS reservations. Therefore, inter-regional schedules with RFC should only include those that have an OASIS reservation. Inter-regional schedules with regions other than RFC are not required to have OASIS reservations.

4.7. Inter-regional Tie Line Coordination

MRO maintains an inter-regional tie line table for use in the power flow process. Any inter-regional tie line entered in a new model series that was not in the previous model series will be verified with the data representative. Inter-regional tie line additions are allowed but must be coordinated with the other region for building ERAG MMWG models. Therefore, all changes to the inter-regional tie lines must be coordinated with MRO staff.

4.8. Shared Generators

When a generator is owned by more than one submitting company, one owner will be responsible for submitting the majority of the generator data required by PSS/E, typically the data representative for the PSS/E area in which the generator physically resides. All owners will coordinate transactions on a case by case basis for the generation (PG) required to supply their load. One data representative will add the generation values of the different owners to determine a combined generation output for the machine for each case in the model series. If the combined PG exceeds the machine's PMAX, the data representative will review ownership shares and identify which owner(s) have submitted data not consistent with their ownership share. An examination of the shared generation prior to the data request due date is advised to ensure compliance.

4.9. Operating Reserves

When scheduling generation, data representatives should make an attempt to minimize the amount of spinning reserve being modeled. Estimates of the spinning reserve are made by calculating the difference between the maximum urge output of your units (sum of PT) and the actual unit output (sum of PG) of all on-line machines. For those with shared units, compare your load to your portion of the gross unit output to estimate the spinning reserve.

4.10. Transmission System Reporting Responsibility

There are presently no restrictions within the MOD database as to which facilities can be added, modified, or deleted by a data representative (i.e. all data representatives have the ability to make changes anywhere within the MRO footprint). Data representatives wishing to modify facility data for which they do not have primary reporting responsibility, or which may impact data submitted by another data representative, should first coordinate with the appropriate data representative to identify who will submit the data change.

You may have reporting responsibility for some transmission data, generation data or facilities that your system may not own or operate. For example, the modeling of

independently owned wind generator complexes and other generation facilities is the responsibility of the data submitter owning the Point of Interconnection bus. The data representative must coordinate collection of the necessary data, internally or potentially via a private facility owner.

4.11. Future Generation and Transmission Facilities

TPSC Forms 1-3 showing each MRO member company's future planned and proposed facility data are posted on the MRO FTP site. Not all of the facilities listed are to be modeled in the series models. Each company should verify that the appropriate future planned and proposed generation and transmission facilities are modeled.

Planned or Proposed Future Generation

Future generation resources, which have not been authorized or sited, must still be modeled if required to serve customer load growth.

- This fictitious generation must be modeled in the same PSS/E area as the load growth it is intended to serve.
- It should be limited to serve only the anticipated load growth indicated in your Entity's EIA-411 submittal, and not increased to model transfers.
- It should be modeled as interconnecting at an appropriate high voltage bus through a generator step-up transformer (GSU). A special naming convention has been adopted for the name of the generator bus (i.e., bus name ends in 'X') to distinguish it from existing or committed units (i.e., bus name ends in 'W' or 'G').

A description of each future generation addition, either planned or fictitious, should be included in the model series documentation.

- Generation Type: Proposed, Planned, Fictitious
- Generator MW Rating
- Cases in which the generator was modeled

The certainty for development of some generation facilities (IPP's including wind sites) and the specific facilities to be used for these projects is not always clear well in advance of construction. It is therefore left as the responsibility of the data representative to decide whether the facility should be modeled in the planning cases. The decision may be based on having a signed Interconnection Agreement or the impact of the facility on the grid. If the project does not proceed it is easier to turn off in the model than it would be for other model users to add the project. More details on wind modeling are available in [Appendix C](#).

Generation scheduled at all existing and future generating units, including an area slack bus, must be within the ratings of the units and initialized properly (i.e., produce a clean STRT) in stability. All generators above 10 MVA, including fictitious generators, are required to have detailed dynamics data (not classical GENCLS). If detailed dynamics data for a unit is not available, it is strongly recommended to substitute with a similar model found in the dynamics 'DYRE' file.

Future generation not required for serving customer load or for meeting MRO planning criteria should not be modeled in the MRO model series unless there is a *good deal of certainty* the project will be completed. Such modeling is left to the data representative's own judgment.

Planned or Proposed Future Transmission Facilities

Future transmission lines and transformers that have not been authorized nor right-of-way purchased may still be modeled. The planned and proposed facilities should be shown with the appropriate numeric circuit "ID". The type of future transmission changes could be:

- Upgrades to an existing transformer or replacement.
- A new substation is being built but the transmission right-of-way has not yet been determined.

A description of each future system upgrade should be included in the model series documentation.

- Upgrade Type: New Facility, Facility Upgrade
- Facility kV and MVA Ratings (include the existing ratings if associated with a facility upgrade)
- Cases in which the upgrade was modeled
- Status of the future projects; planned, proposed, under construction

4.12. Planned

Planned projects are those for which a system condition has been found to violate applicable planning standards, and the planned project has been determined by the transmission owner to be the recommended project from among alternatives. Planned projects may be in various stages of corporate internal and external approval processes.

4.13. Proposed

Proposed projects are those for which a system condition has been found to violate applicable planning standards, and the proposed project is the best-known alternative at this time. These projects have not yet been clearly defined and additional study is needed before the transmission owner recommends the proposed project as a new plan.

Note: the transmission owners should not be reluctant to include Planned or Proposed upgrades in the models out of concern that these upgrades will be used inappropriately to sell transmission service, or that the Transmission Owner will not have an opportunity to withdraw or modify a plan that can be demonstrated at a later date to be no longer effective or necessary.

4.14. Exploratory

In general, exploratory projects should not be modeled. Exploratory Projects are those that may provide an economic benefit, but do not necessarily address an identified system condition that has been found to violate applicable planning standards.

An Exploratory Project that has been through the appropriate planning process, has TO support, and has a strong certainty of completion could be included in the MRO Series Models. This type of project should be highlighted in the model series documentation to ensure all model users are aware of its inclusion in the models.

4.15. Power Flow Model Development Guideline

Bus, Zone, and Area Numbering Convention

The MRO model building process includes a standard modeling convention for bus, zone, and area numbering for each system's individual buses.

The standard method is:

1. If your system owns the bus, your system's bus number and zone number are applied to the bus.
2. If the bus is in your system's area and you own the bus, your system's bus, zone, and area numbers are applied to the bus.
3. If your system owns the bus and the bus is in another system's area, then assign your system's bus and zone numbers and assign the area number of the system where your bus physically resides.

In general, your bus and zone numbers would be assigned to a bus owned by your company. The area number of the area where the bus is physically located will be assigned to the bus, independent of who owns the bus.

A. Bus Data

Bus data should follow the guidelines of PSS/E (see PSS/E Operation Manual).

MMWG had assigned the MRO region the bus number range from 600,000 through 699,999. A breakdown of the individual company bus ranges, AREA, ZONE, and OWNER numbers are shown in [Appendix A](#). Each data representative should strive to follow these guidelines:

- Each bus should retain the same name and number throughout the model series and from series to series.
- All bus names must be unique throughout both MRO and MMWG data, and will be checked by the MRO representative on the MMWG.

Bus name voltage codes can be changed in the same series of models but it is expected that the rest of the name remain constant.

Bus names may be up to twelve characters and must be enclosed in quotes. The name may contain any combination of blanks, uppercase letters, numbers, and special characters, with the first character being alphabetic rather than numeric (must not

begin with a minus sign). The name should be left justified. The last character field of the bus name shall be the MRO voltage code (see table below).

Bus Name Voltage Code			
#	kV	#	kV
1	- 765	6	- 138
2	- 500	7	- 115, 110
3	- 345	8	- 88, 72, 69, 63.5
4	- 230	9	- < 63.5
5	- 161	G	- Generator Terminal
W	- Wind Turbine Generator	X	- Future Generator Unit
Y	- Midpoint on Transformer		

B. Load Data

Load data should follow the guidelines of PSS/E (see PSS/E Operation Manual).

Each data representative should prepare data consistent with its most recent official system forecasts in all data submitted to MRO including EIA-411 information. To properly coordinate with the ERAG Inter-regional power flow model development, in no instance should loads be reduced for wholesale application of controllable demand-side management, curtailment of interruptible loads, or for emergency procedures such as voltage reductions and the anticipated effects of public appeals. The effects of uncontrolled demand-side management (peak shaving) should be reflected in the load of summer and winter peak load cases.

The LOAD ID is used to distinguish among multiple loads at a bus, and is specified by a two character uppercase alphanumeric designation. The company LOAD ID, AREA, ZONE, and OWNER are defined in [Appendix A](#). With model solutions consisting of Area Interchange enabled using “Tie lines and loads”, the reported load should have the AREA number representing the owner’s PSS/E area. Each data submitting company is assigned a load OWNER number unique to that company. Each bus load type must have a unique LOAD ID, so MRO defines a LOAD ID using the first character to specify the load owner and the second character to specify the load type. The load types are as follows:

- Load of 0 is used for Seasonal Firm
- Load of 1 is used for Seasonal Interruptible
- Load of 2 is used for Constant Firm
- Load of 3 is used for Constant Interruptible
- Load of 4 is used for Conditional or Station Service Load
- Load of 5 is used for Transmission Interruptible

When scaling the area load representation, it is important to consider the reactive power as well as the real power. This is particularly true when referencing a case of a different season. Realistic reactive load representation has a major effect on the overall case voltages. Reactive requirements are different for the various seasonal cases.

Loads of a unique PSSE Owner (company) must be assigned one, and only one, host PSSE Area. The host PSSE Area will typically contain most of the resources to serve a company's load, but not necessarily. **Transactions will not be used to serve external area loads when solving models with the area interchange control enabled and set to "Tie lines and loads"** (see diagrams below).

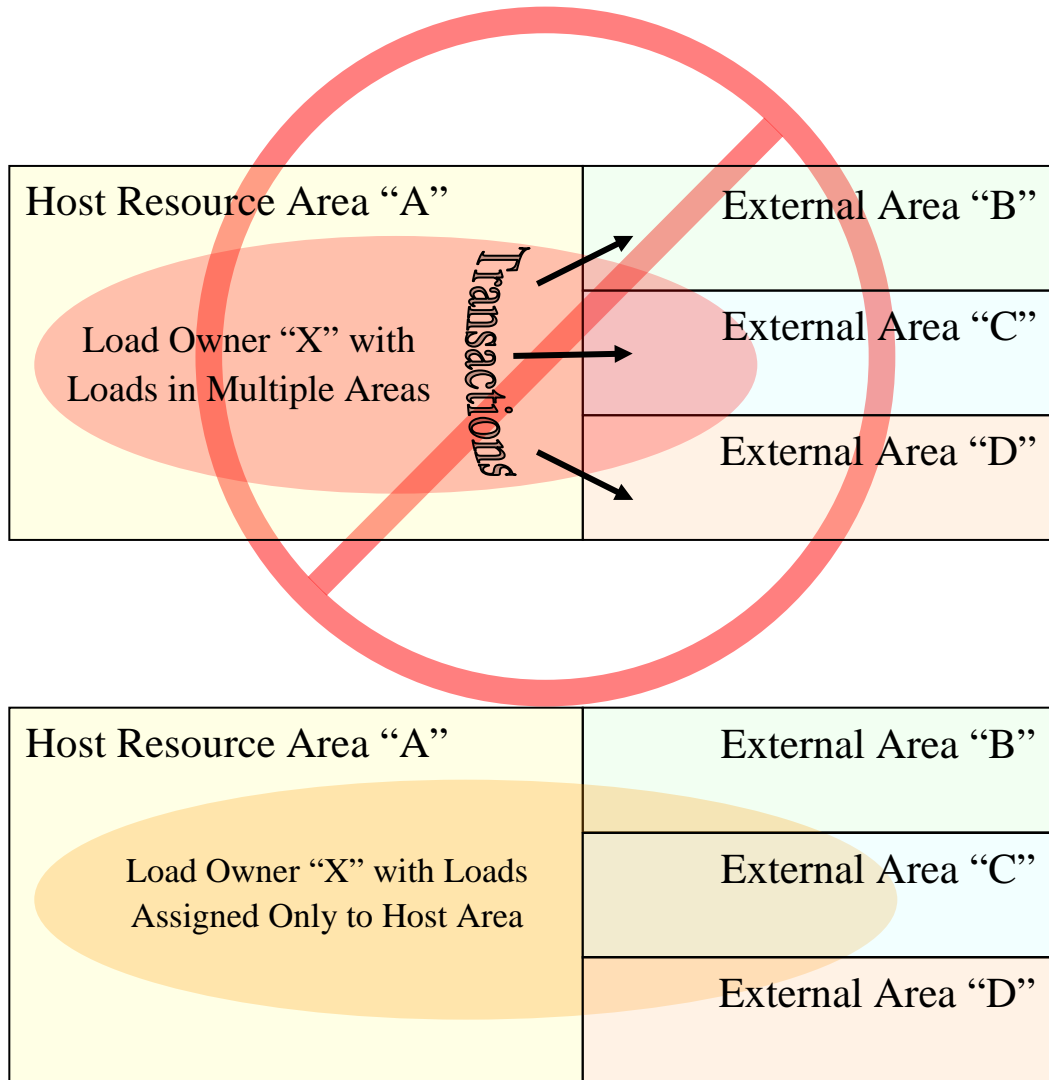

C. Generator Data

Generator data should follow the guidelines of PSS/E (see PSS/E Operation Manual).

C.1. Guidelines for modeling Wind Turbine Generator (WTG) plants

Wind generation, generally modeled as an aggregate machine representing many wind turbines, has special modeling considerations due to differences from conventional machines. Supporting detail for modeling WTG plants is provided in [Appendix C](#).

C.2. Guidelines for modeling relatively small units and plants

The smaller units at a particular bus may be lumped together and represented as one unit (this is recommended for WTG plants). Lumping of generating units as a station is acceptable where they have the same electrical and control characteristics. Otherwise, they may be lumped into several machines, each representing two or more similar units. Units equal to or greater than 50 MVA should not be lumped together and equivalent lumped units should not exceed 300 MVA.

Units or plants equal to or greater than 10 MVA (except wind) should be explicitly modeled and represented with detailed data. The MBS recognizes that under certain conditions a unit greater than 10 MVA could be netted with load without adversely impacting the BES behavior. Therefore, the owner may request that the MBS waive the guideline specifying that the unit be modeled.

C.3. Guidelines for generator station modeling

To distinguish the type and firmness (future) of the generation resource, the bus name for a generator bus should end in one of three special characters, as shown below.

- ‘W’ for existing or committed future wind turbine generator⁵,
- ‘G’ for other existing or committed future generator, and
- ‘X’ for future generation that is not authorized or sited.

Future generation that has not been authorized or sited must still be modeled, if required to serve customer load growth. This fictitious generation must be modeled in the same PSS/E area as the load growth it is intended to serve. It should be modeled as interconnecting at an appropriate high voltage bus through a GSU (With the generator bus name ending in 'X').

The valid 1 to 2-character unit identifiers for wind generators are W and W1 through W9. Since these generally reflect aggregate representation for many units, 9 ID's per bus is expected to be sufficient. For other generators the valid identifiers are 1-99 and A-Z, excluding W. The unit identifier should remain the same for the power flow series and consistent from year to year.

The ZSORCE data provided in the power flow cases must match the dynamics data.

A generator that is out-of-service should be modeled with a STATUS = “0” in the power flow model. The modeling technique of using bus type code 4 to disconnect the generator while leaving the PGEN value non-zero would be an invalid representation.

C.4. Guidelines for modeling generator step-up (GSU) transformers

The GSU transformers should be represented explicitly for all units in MRO that have a name plate rating of 70 MVA and greater or units deemed significant by the company responsible. PSS/E does allow the modeling of GSU transformers within

⁵ Conventions for bus name and generator unit identifier associated with WTGs provide easy recognition of wind resources in the model to facilitate adjustment of regional wind dispatch.

generator data fields or implicitly. Implicit GSU data should be on the generator MVA base, not the GSU base or system base. Preference is for explicit GSU representation of larger units. Whether the GSU is modeled explicitly or implicitly, care should be taken to ensure the step-up transformer taps and impedance have been specified with the modeled tap on the high voltage side and that the values account for any difference between rated generator terminal voltage and the rated voltage of the transformer at the particular off-nominal setting of the tap.

A GSU should be represented explicitly for WTG applications. This would be a net representation of many GSUs if the generator similarly is an aggregate machine representing many local WTGs. The aggregate transformer for the WTGs can be modeled using the PU impedance of a single transformer, and scaling the transformer MVA base to match the size of the wind farm.

A GSU should be represented explicitly for all cross-compound units to ensure accuracy in representing these units.

The correct tap ratio must be used for GSU, which is not always 1.0.

The voltage should be regulated no farther away than the high side bus of the GSU. The low side of the GSU is the preferred regulated bus.

C.5. Guidelines for modeling real power capability defined with the generator data:

- PG: Generator real power output, entered in MW.
- PT: Maximum generator real power output, entered in MW.
- PB: Minimum generator real power output, entered in MW.

The generation real power capability limits should represent a realistic unit output capability at the bus on which the generator is modeled. Also, PT should always be greater than or equal to PB. The generation capability limits should represent gross output if the station service load is modeled, otherwise, the net output should be modeled. The PT and PB limits should also take into consideration the generator step-up transformer losses if the GSU is not explicitly modeled.

Mbase times Pmax of the associated stability governor model should be greater than or equal to 105% of PT to avoid governor initialization problems in dynamics.

Wind energy is recognized as a variable and unpredictable resource. However, for consistent base case modeling, it is recommended that WTG generation dispatch (PG) levels, as a percent of installed capacity, based on system load levels are:

<u>NERC/MRO Season</u>	<u>Peak Load</u>	<u>Shoulder or Light Load</u>
Spring	35%	35%
Summer	20%	35%
Fall	35%	35%
Winter	35%	35%

The data representative may elect to turn their WTG's off for summer peak or winter peak conditions, rather than adhere to this recommendation, if their machines are not equipped or expected to operate under peak load ambient conditions (extreme heat or cold).

C.6. Guidelines for modeling reactive power capability defined with the generator data:

- QG: Generator reactive power output, entered in MVAR.
- QT: Maximum generator reactive power output, entered in MVAR.
- QB: Minimum generator reactive power output, entered in MVAR.

The generation reactive power capability should represent realistic plant output capability at the bus on which the generator is modeled, and often is the reactive power at rated conditions. Also, QT should always be greater than or equal to QB. The generation capability limits should represent gross output if the station service load is modeled, otherwise, the net output should be modeled. The QT and QB limits should also take into consideration the generator step-up transformer losses if the GSU is not explicitly modeled. Options to apply reactive power limit values in relation to or by modeling a machine's capability curve are discussed in section C.8.

Mvar limits for a WTG plant are based on the type of machines and applied voltage control strategy, as detailed in [Appendix C](#).

Using a generator for voltage support only, with no real power output, should be avoided unless this represents actual operation, as would be the case if the machine represents a synchronous condenser or static Var compensator. Regulating transformers should not be located at a bus with a controlling generator.

C.7. Guidelines for modeling Station Service Load (SSL):

Station Service Load (SSL) should be modeled for all on-line generators that are modeled on the low side of the GSU transformer. SSL should be modeled on the terminal bus and reflect the load at maximum generator output during the URGE tests. The data representative with primary responsibility for reporting a jointly owned unit should also report the SSL for that unit. Where SSL is modeled, generation schedules are defined to be Gross at the bus where the generator is modeled. SSL is not part of a company's load forecast.

C.8. Guidelines for adding a generator to the models:

Guidelines for modeling a GSU and its associated terminal bus were noted above. In the event a terminal bus must be added, the conventions below should be followed.

The company responsible for modeling the terminal bus should determine the new terminal bus name, recognizing that the last two characters will be the unit number and the character 'W' (for wind) or 'G'. For example generator bus name 'COOPER1G' has the letter 'G' as the final character in the name. This naming convention identifies the bus as a generator. Future generators that are not authorized or sited should have an 'X' as the last character to identify the generator as planned.

All generators used for OASIS schedules must be represented in the MRO model series.

The PT (i.e., PMAX) should match the historical maximum rating based on annual URGE testing of the generator. The gross generator output should be used for PT if the Station Service Load is being modeled, otherwise, the net generator output should be modeled.

The QT and QB (i.e., QMAX and QMIN) should match the generator's overexcited and underexcited reactive capability, respectively. The data representative should always verify that the generator can deliver its Qmax at its real power output. Qmax is often the reactive power at rated conditions, and creates a rectangular generator capability curve. However, this modeling approach does not account for all available reactive power when generators are operated below rated real power. This modeling inadequacy is more significant when modeling generators with high rated power factor (95%) and high synchronous reactance. This can be overcome by providing MRO with auxiliary data to model a machine's capability curve. This data will be distributed with the models and can optionally be used by study personnel.

Figure 1, provided below, shows a typical generator reactive capability curve. It plots the gross MW capability versus the Mvar capability of a machine including both overexcited (+Q) and underexcited (-Q) values.

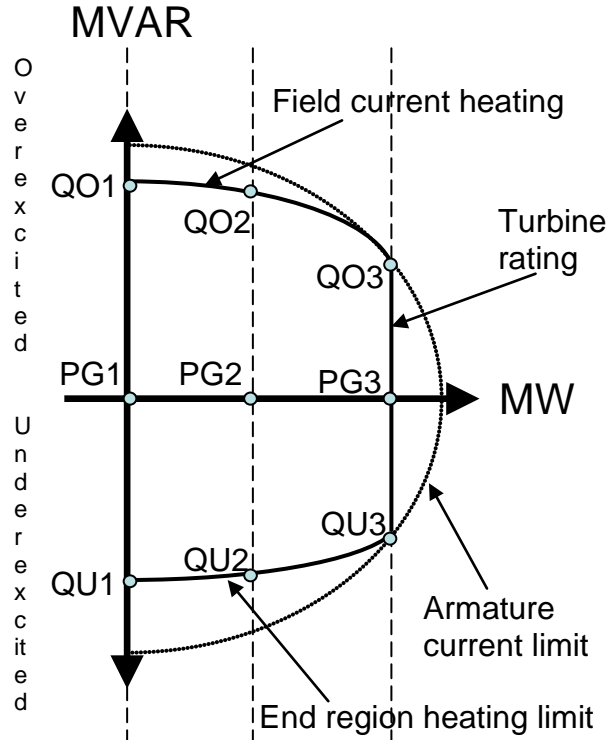

Figure 1 - Typical Generator Capability Curve

The PSS/E power flow program has traditionally allowed a user to model generator capability in terms of Pmax, Pmin, Qmax and Qmin. Recent versions of PSS/E allow the user to model *up to 10 sets of points* along the capability curve via a supplemental data file. As an example, three sets of points are shown in Figure 1 where $QO_i = Q_{max}$ and $QU_i = Q_{min}$ at the associated real power output PG_i . Mvar limits can then be updated in PSS/E based on generator MW output in a specific power flow case via activity GCAP. It is recommended that data representatives provide this data as a resource for study personnel within MRO.

The machine capability curve data has the following format:

I, ID, P1, QT1, QB1, P2, QT2, QB2, ... P10, QT10, QB10

Where:

- I Bus number
- ID One or two character machine identifier
- Pi Generator active power output along the “MW” axis of the machine’s capability curve.
- QTi Maximum (i.e., overexcited) reactive power limit at Pi MW, entered in Mvar

QBi Minimum (i.e., underexcited) reactive power limit at Pi MW, entered in Mvar

Up to 10 sets of points on the capability curve may be entered. When the machine is a generator, the Pi values must be in ascending order with P1 greater than or equal to zero. When the machine is a motor, the Pi values must be in descending order with P1 less than or equal to zero.

If only one set of data is provided, it must be entered in the P1, QT1 and QB1 data fields of the GCAP input file.

If three sets of data are provided, they must be entered in the first three data set fields of the GCAP input file.

If the data representative cannot provide additional data for the supplemental data file, the minimum conservative MW and Mvar limits required to model a generator (Pmax, Qmax and Qmin) are points PG3, QO3 and QU3 in the sample curve. These values should be used for PT, QT, and QB in the power flow representation of the generator. To ensure realistic limits are provided, it is necessary to model points along a vertical line intersecting the capability curve. Therefore, PG3, QO1 and QU1 are not an appropriate set of values.

D. Non-Transformer Branch Data

Branch data should follow the guidelines of PSS/E (see PSS/E Operation Manual).

I is the branch “from bus” number. For a transformer, this is the tapped side bus. J is the branch “to bus”. CKT is a two character uppercase nonblank alphanumeric circuit identifier.

D.1 Guidelines for modeling branch data

The impedance data should be specified on a 100 MVA base (a resistance of zero is acceptable). However, the reactance must remain above the zero impedance threshold tolerance of 0.0001 P.U. A reactance less than or equal to the threshold value will result in PSS/E treating the branch as a zero impedance line

PSS/E can model bus ties, jumpers, and other low impedance branches as zero impedance branches. A zero impedance branch has the following characteristics:

- Its resistance must be zero.
- Its magnitude or reactance must be less than or equal to the zero impedance line threshold tolerance, THRSHZ.
- It must not be a transformer.

However, all ‘valid’ zero-impedance branches (such as bus ties or switches) must be modeled with a resistance of $R = .0001$ and a reactance $X = 0.0002$ PU to distinguish them from invalid zero impedance branches that may have been inadvertently added to a model.

Branches with large negative reactance (< -3.0 P.U.) do not represent real devices, and should not be modeled.

Where network representation has been equivalized, a maximum cut-off impedance of 3.0 P.U. should be used.

MRO has adopted the following definitions for the PSS/E branch ratings definitions:

- Rate A: The seasonal minimum normal rating of conductor, transformer, or equipment
- Rate B: The seasonal minimum emergency rating of conductor, transformer or equipment
- Rate C: The seasonal conductor or transformer rating and should be greater than or equal to Rate A

E. Transformer Data

Transformer adjustment data should follow the guidelines of PSS/E (see PSS/E Operation Manual).

E.1. Tap Changing Transformers

If tap changing under load (TCUL) transformers are modeled, the tap step size should be no smaller than 0.00625 P.U. and the controlling voltage band should be at least two times the tap step size. The power flow report should be checked for tap settings. Particular attention to LTC-equipped transformers should be given to make sure the proper bus is regulated. The transformer tap and tap limits should be specified. Using LTC transformers for local area voltage control where no such transformer actually exists should be avoided. Regulating transformers should not be located at a bus with a regulating generator.

A tap setting of less than 1.000 on the tap bus results in an increase in voltage on the non-tap bus. A tap setting greater than 1.000 on the tap bus results in a decrease in voltage on the non-tap bus.

The inclusion of LTC regulation makes tap setting more important. With LTC-equipped transformers, fixed taps may also exist. The LTC tap range should be adjusted to compensate for the effects of fixed taps if necessary.

E.2. Phase Shifter Models

Phase shifter sign conventions must be adhered to in all models. The MW tolerance for phase-shifting-under-load transformers should be no less than ± 5 MW (i.e., a 10 MW dead band).

F. Area Interchange Data

Area Interchange data should follow the guidelines of PSS/E (see PSS/E Operation Manual).

All areas in the MRO cases are to have proper area names and numbers for identification, consistent with the standard area number/area name designations. The MBS must approve any changes to the number of areas in a system, and the data representatives should advise the MBS members of any proposed changes to [Appendix A](#) so the database changes can be implemented. Each area should have an on-line slack machine for each model.

G. Two-Terminal dc Transmission Line Data

Two-Terminal dc Transmission Line data should follow guidelines of PSS/E (see PSS/E Operation Manual).

H. Voltage Source Converter (VSC) Dc Line Data

Voltage Source Converter (VSC) DC Line data should follow the guidelines of PSS/E (see PSS/E Operation Manual).

I. Switched Shunt Data

Switched shunt data should follow the guidelines of PSS/E (see PSS/E Operation Manual).

MODSW is the control mode that is defined as follows:

- 0 – Fixed
- 1 – Discrete adjustment, controlling voltage locally or at bus SWREM
- 2 – Continuous adjustment, controlling voltage locally or at bus SWREM
- 3 – Discrete adjustment, controlling reactive power output of the plant at bus SWREM
- 4 – Discrete adjustment, controlling reactive power output of the VSC dc line converter at bus SWREM of the VSC dc line whose name is specified as RMIDNT

SWREM is the bus number of a remote Type 1 bus whose voltage is regulated by this switched shunt to the voltage specified by VSWHI and VSWLO. Each reactor Bi is specified with a negative quantity, and each capacitor Bi is specified with a positive quantity. An automatically switched shunt may be set up at any bus, but they are recognized as being in service only at a Type 1 buses and fixed generator output Type 2 buses. Switched shunts are assumed fixed at a value of BINIT at voltage-controlling Type 2 and 3 buses.

As discussed in [Appendix C](#), power factor correction capacitors associated with WTG's and any additional wind farm var compensation should be explicitly modeled.

J. Transformer Impedance Correction Tables

Transformer impedance correction data should follow the guidelines of PSS/E (see PSS/E Operation Manual).

K. Multiterminal DC Transmission Line Data

Multiterminal DC transmission line data should follow the guidelines of PSS/E (see PSS/E Operation Manual).

L. Multisection Line Grouping Data

Multisection line grouping data should follow the guidelines of PSS/E (see PSS/E Operation Manual).

M. Zone Data

Zone data should follow the guidelines of PSS/E (see PSS/E Operation Manual).

MRO must use zones, consistent with the MBS zone number ranges assigned by MBS (see [Appendix A](#)).

N. Inter-area Transfer Data

Inter-area transfer data should follow the guidelines of PSS/E (see PSS/E Operation Manual).

Note that transactions are not entered into the MRO series models, but are retained in the Model Building Database. Access to transaction information is restricted, so users of the MRO series models must request the transaction data.

O. Owner Data

Owner data should follow the guidelines of PSS/E (see PSS/E Operation Manual).

P. Facts Control Device Data

Facts control device data should follow the guidelines of PSS/E (see PSS/E Operation Manual).

5. Dynamic Model Development

The data representatives submit the dynamics data and the corresponding power flow data, which are used to create dynamics simulation cases. In general, only a single dynamic snapshot is created for a power flow series. This process is repeated annually for each MRO model series. Classical data may not be submitted when detailed data is not available. Typical data as shown in [Appendix B](#) or a close proximity from an existing detailed dynamic data of another machine shall be submitted when detailed data is not available.

In order to accurately simulate the performance of the interconnected electric systems, only detailed dynamics models are utilized. Conventions regarding the representation of the various system elements are determined by the MBS. The objective is to provide intra-regional dynamic databases and dynamics simulation cases that can be used to accurately evaluate the performance of the MRO region and that can be assimilated with the inter-regional dynamic database.

5.1. Model Definition

A single PSS/E stability data set (SNAPSHOT file) is built. This SNAPSHOT file contains dynamic models compatible with all the power flow models associated with the MRO Series in the version of PSS/E identified for that particular model series.

Any given model, if supported in the target version of PSS/E, can be submitted for a given unit.

5.2. Data Submitter Model Development Guidelines

1. Data representatives must verify new dynamic data before submission to MRO by:
 - a) running a 20 second steady state run with the actual data
 - b) performing governor response tests with PSS/E activities (GSTR, GRUN)
 - c) performing excitation tests with PSS/E activities (ESTR, ERUN)
2. The dynamic data submitted to the MRO Series should be detailed data which includes; generator, excitation system, and governor models as well as other models (user defined, motors, load, stabilizers, relays, etc.). Some typical data parameters are shown in [Appendix B](#).
3. The models should be compatible with a standard 1/2 cycle integration time step.
4. The dynamics database should be capable of handling schedule changes for HVDC terminals (forward and reverse modes) and pumped storage generation (generating and pumping modes).
5. The dynamic database format is compatible with the power flow cases. Currently, the power flow cases are developed using the PTI PSS/E format. A specific version of PSS/E is stipulated by the MBS for each model series.
6. Dynamics data must be provided in machine MVA base.
 - a) The machine data must be supplied using its own machine base as represented in the power flow cases as MBASE on the generator data. The machine BASEKV must also be represented correctly.
 - b) Zsource data provided in the power flow cases must match the dynamics data.
7. Units not dispatched must be modeled with a status "0", or off-line, in the power flow model. Units that are not dispatched should be represented in the model for

completeness of data as well as to facilitate simulation of other operating scenarios.

8. Machine data checks:
 - a) Realistic values should be used for P_{MAX} (governor), P_{MIN}, Q_{MAX}, and Q_{MIN}. Use of PSS/E default values should be avoided in both power flow and dynamics data.
 - b) The following are examples of screening checks to be performed on the power flow model used in association with the dynamics data:
 - $P_{gen} + j Q_{gen} \geq 115\%$ of MVA base
 - $Q_{MAX} \geq Q_{MIN}$.
 - Z_{source} data provided in the MBS power flow matches the dynamics data.
 - c) The following are examples of screening checks to be performed on the dynamics data:
 - Inertia constant not equal to zero.
 - Generator reactance data is unsaturated.
 - Activities DOCU, ESTR, ERUN, GSTR, GRUN, and VCHK.
9. Station service/auxiliary load representation is requested for very significant loads. Accurate dynamics simulations require the representation of detailed station service loads (e.g. induction motors).
10. The appropriate load model representation for dynamics (i.e., constant P, Q, I, & Z) should be provided by each region for its respective areas. The MRO typically uses 100% constant current for real power and 100% constant admittance for reactive power.
11. Each data representative should provide an IDEV file specifying their desired output channels.

5.3. Guidelines for Wind Turbine Generators (WTG)

Detailed discussion on dynamics modeling for WTGs is provided in [Appendix C](#).

5.4. Steps for Receiving Dynamic Data

The following steps are taken with every received data representative's dynamic data:

1. The data are "logged in."
2. The data are read and saved in a file for conversion to the required format used by the MRO staff for stability database and calculation.
3. Area names, area numbers, zone number ranges, and bus number ranges are checked for compliance with those in [Appendix A](#).

5.5. Dynamic Model Development

The dynamic model is built and tested by MRO staff, using PTI's PSS/E program. All files necessary to run this model are provided to the MRO.

The Dynamic Model is built from the MRO database (or data files) and any user written models (i.e. CMHDC3, SUVC, UDCHLD, UDCHLR, and DCRED1), provided by the data representative's. Documentation is available for all non-PTI models used in the SNAPSHOT file.

5.6. Dynamic Data/Model Screening During Model Development

The following steps are observed during the process of creating dynamics simulation cases.

1. Perform initialization based on DYRE, CONEC, CONET and RAWD Files. Read in each of the power flow RAWD data, including all machines for the power flow series, into a single PSS/E power flow.
2. Obtain the DYRE file from the dynamics database. This file includes the external system data from the latest ERAG MMWG model, plus updated internal MRO region data based on the current data submission. Using the PTI PSS/E dynamics simulation skeleton program, read in the converted power flow case above.
3. Perform activity DYRE and read in the DYRE dynamics data file. Note and document any warning and error messages that are displayed.
4. Perform activity CHAN and read in the Channel data file. Note and document any warning and error messages that are displayed.
5. Create the SNAPSHOT, CONEC and CONET files and compile command procedure before exiting the PSS/E dynamics simulation program. Resolve any problems indicated by the activity DYRE by coordinating with the data submitting company and/or the MBS.
6. Add the user-written source codes to the respective CONEC and CONET files and execute the compile command procedure previously created. Execute CLOAD4 to link the files, thereby creating a user version of the PSS/E dynamics simulation program.
7. Using the user version of the PTI PSS/E dynamic simulation program, read in the SNAPSHOT file and solved power flow case. Solve the AC power flow case. Run the Sidney DC and the Watertown SVC conversion IPLAN program. Solve the power flow case. After the AC solution, convert the generators and load using the CONG and CONL activities. Apply appropriate percents of constant impedance, constant current and constant P/Q loads with the CONL conversion process. Perform activities FACT and TYSL. Perform activity STRT. Note any problematic messages (e.g., missing dynamics data, or Zsource different than X'd). Note any states that are not initializing properly, i.e., any dynamic states whose derivatives are not zero, within the standard tolerance. Document and correct these problems. Repeat this until all initialization problems have been corrected.
8. Once all the dynamic initialization problems have been corrected, using activity RUN execute the dynamic simulation for 20 seconds, unperturbed, using a standard 1/2 cycle time step. Assess the steady-state stability of the dynamic simulation run by various relative machine angles, the outputs of the "TOTA" and "SYSANG". Adjust the integration time step (only upon MBS approval) and/or correct data until the dynamic simulation (unperturbed) is judged to be steady-state stable.
9. To further verify the model integrity, it should be tested under non-extreme contingency conditions at various locations (two per MBS area). The MBS area representatives will provide corresponding switching information.

5.7. Final Dynamics Deliverables

MRO staff will provide the following to the MRO data representatives:

1. Dynamic Power Flow Cases - Initialized steady state and MBS area contingency cases.
 - a. Dynamic Power Flow RAWD case file
 - b. Conversion IDEV files
2. Dynamics input data and output files and instructions.
 - a. Input Data
 - Machine input data DYRE file
 - Flex code for user defined models
 - CONEC/CONET files
 - Bind script file
 - Load conversion CONL file sorted by area
 - Idev file for each case to correct any deficiencies necessary to run dynamics
 - Sample simulation run files for each power flow
 - Output channel IDEV file
 - Sample simulation plotting files for each power flow
 - b. Output Files and Instructions
 - Listing of acceptable non-zero "D states"
 - Output channel IDEV files for initialized steady state and MBS area contingency cases
 - Report
3. Data Files Description
 - a. MRO stability packages will generally be built using the folder layout shown in Figure 2.

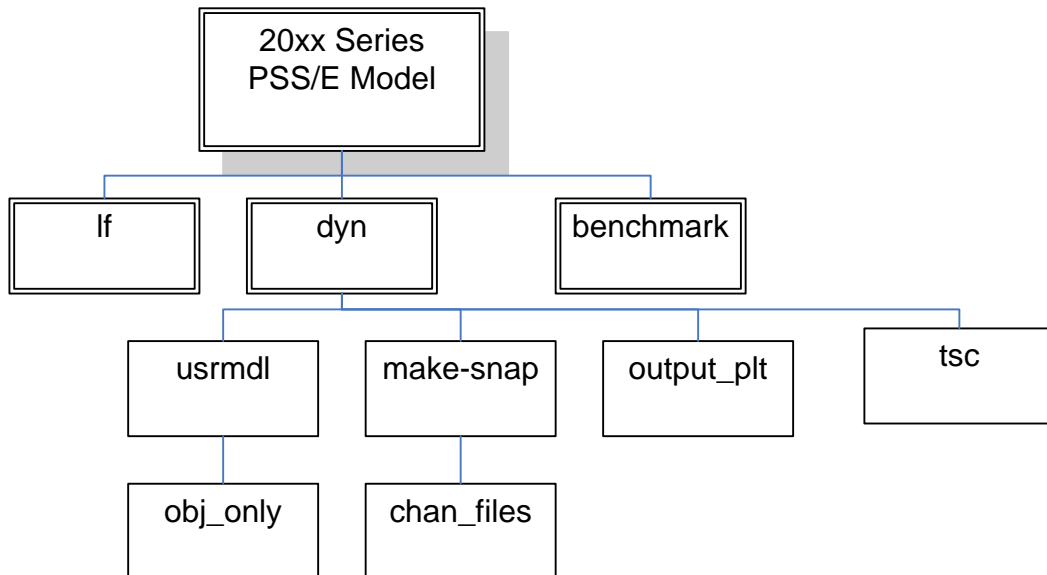

Figure 2 - Typical Package Installation folder structure

Files associated with the MRO Stability Model are the following:

In dyn:

File Name	Description
MROyy.snp	Snapshot
MROyy.dyr	Source form Snapshot DYRE I/P data
MROyycc.flx	CONEC
MROyyct.f Ix	CONET
compileyy.sc	Compile Script for conec and conet
cloadyy.sc	Bind script
conec.o	Compiled CONEC
conet.o	Compiled CONET
mmyy.pssds	Dynamic skeleton
docuyy.dat	Model documentation of dynamics

In dyn\usrmdl:

These files are special non-standard user written PTI PSS/E models to be included in the snapshot. All models are compatible with PSS/E, though not all are presently 'USRMDLs'. The necessary files are compiled by compile.sc and loaded by cloadyy.sc (in dyn/make-snap folder)

In dyn\tsc:

These files are a record or transcript of the start (STRT) and Run dialogue created during a dynamics simulation testing. File names are self-explanatory. Suffix (sc) designates a script file.

In dyn\output_plt:

This folder contains the binary output files created during a dynamics simulation and the plotting files to produce a standard set of plots of the simulation results. It also contains the relay overlay data file for R-X plots included in the standard plot set.

In lf:

These are the power flow saved cases (suffix .sav), compatible with the Stability model. File names are self-explanatory.

In benchmark:

Simulation files and results for MRO region disturbances run on several power flows as a model sanity check.

Test Results

STRT and Steady State Run Test

Each power flow case is tested with the snapshot by performing a STRT and 20 second steady state run.

6. Preparation and Transmittal of Member Data

1. All power flow, dynamics, and short circuit data should be submitted in accordance with the guidelines described in this manual and the Annual Data Request.
2. Area names, area numbers, zone numbers, bus number ranges, transformer impedance correction tables, and dc line numbers must conform to the company's assigned values (see [Appendix A](#)).
3. All areas in the MRO cases are to have proper area names and numbers for identification, consistent with the standard area number/area name. The MBS must approve any changes to the number of areas in a system. All such changes to the next model series must be made prior to June 1 since these changes must also be made to the model building databases.
4. Zone numbers must conform to the company's assigned range.
5. Cases are to be received by the model building contractor according to the approved schedule.
6. Transmitting data to the model building contractor must be done via the MOD database or by e-mail as necessary.

7. Model Documentation

MRO staff will post the Model Documentation for the final models after the dynamics and the short circuit model are complete. Some of the items included in the Model Documentation are:

7.1. Power Flow Model Documentation

1. General information about the models.
2. Area Appraisals: Compilations, by MBS members, of noteworthy model changes and assumptions provided by data representatives. MBS areas are geographical in nature as prescribed in the MRO-MBS Charter. MBS areas are **not** associated with: company, balancing authority, model area, subregional planning group, transmission planner, transmission owner, transmission provider, tariff administrator, or any other such entity. Data representatives often submit modeling which notably impacts more than one MBS area, but may choose to coordinate documentation with just one MBS member. MBS members shall interchange, without solicitation, modeling documentation which is relevant to other MBS area responsibility. In some instances, MBS members may request additional information or narrative from data representatives or other MBS members to adequately describe substantive modeling changes or assumptions.
3. Table of Inter-regional Tie Lines: This list shows the status of the inter-regional tie lines in each of the power flow models.

7.2. Dynamic Documentation

1. Includes documentation of user models (Model sheets, model description, and user notes) and CON, ICON, VAR, and State numbers for the user models.
2. Important file names including snapshot file, CONEC and CONET, dyre, SSRUN (Plot and run script for each of the 15 models), etc,
3. Initialization problems and fixes.

7.3. Short Circuit Documentation

The MRO MBS does not currently develop Short Circuit models.

8. MBS Compliance Program

Included in the program are two measurements that apply to the MRO Region for which the MBS has compliance review responsibility. The data request letter is to be considered a formal request for compliance materials associated with the subject measurements. A tracking process has been set-up to record timing issues that may occur. The MBS will also log the data errors that delay the process of base case development.

The schedule for Power Flow and Dynamics Development data is on the MRO website at http://www.midwestreliability.org/REL_model_building_schedule.html.

8.1. Compliance Timing Issues

To enforce the timing issues the MBS will follow this sequence:

- MRO staff will monitor that each company has confirmed receipt of the data request, and send a message to the MBS confirming a response from each company.
- Two weeks prior to the submittal deadline – the MBS Chairman may schedule a- conference call (if needed) of the MBS to review any problems with the database or special data submitting issues.
- One week prior to the submittal deadline - MRO staff will email to the data representatives a reminder of the due date and indicate any known problems with the database.
- Submission deadline is 12:00 AM (Midnight) Central Time on the due dates listed in the schedule. MRO staff will verify the receipt of information.
- All requests for deadline extensions must be submitted to the MBS (mro-models@midwestreliability.org) at least 5 working days prior to the deadline. The MBS will arrange a conference call to review the extension request. Extensions will only be given under special circumstances beyond the control of the data representative.
- MRO Assessments staff will file a complaint with the MRO Compliance Department if an entity does not submit their data according to the approved schedule. The MRO Compliance Department will investigate the complaint and determine whether the entity has violated a requirement and take the appropriate actions.

8.2. Compliance Quality Issues

To enforce the quality issues the following will be used:

- The PSS/E Activities report must not contain errors unless the data representative submits written validation in their email confirmation to the MBS (mro-models@midwestreliability.org).
- Any data submittal not meeting the requirements listed in this manual and data request instructions may be returned for correction and the company will be subject to being reported as being late in its submittal.
- Future generation and transmission modeling should conform to the policies adopted in this manual.

- Data using default PSS/E values of 9999 MVA, in required data files, are not compliant unless such default data values are used correctly (i.e. SVC's PGEN data and the like).
- Incomplete data sets such as generators with MBASE and ZSORCE = 0, Pmax < Pmin, 69 kV and above branches without all ratings, or missing topology, are not compliant.
- Confirm that your company's load data is consistent with the EIA-411 data. If not, an outline of the major differences is required.
- Each bus, 115 kV and above, should maintain the same unique name, as adopted in this manual, throughout the model series. Each generator bus should use the approved naming convention.
- Dynamics data is required for all new units above 10 MVA. The machine data should be a detailed representation, not a classical representation.
- Each dynamics case shall have a 20 second no disturbance flat line response.
- In accordance with PTI PSS/E requirements, the Xsource value in the powerflow generator data record shall be as follows:
 - Xsource = X" d for detailed synchronous machine modeling
 - Xsource = X' d for non-detailed synchronous machine modeling
 - Xsource = 1.0 pu or larger for all other devices
- Inertia constant is nonzero.
- All valid zero-impedance branches must be modeled with a resistance of R = .0001 and a reactance of X = .0002.
- All CNTB errors, lacking documented exceptions, shall be fixed, exceptions will be documented (DSMES units) and warnings shall be reviewed for validity.

8.3. Non-Compliance and Levels of Non-Compliance

Refer to the applicable FERC Approved Reliability Standard to determine the levels of non compliance.

- MOD-010-0: Steady-State Data for Transmission System Modeling and Simulation
- MOD-012-0: Dynamic Data for Transmission System Modeling and Simulation

The MRO has a compliance web site with FAQs and other information and resources. The MRO compliance process is documented in the Compliance Monitoring and Enforcement Program (CMEP) document posted on the MRO website.

http://www.midwestreliability.org/COMP_cmep.html

Appendix A - Systems Codes for Power Flow Data

MRO Company Name	Co.	Area #	Owner #	Min	Max	# of Buses	# of Zones	Zone Min	Zone Max	Load ID	AREA
Northern States Power	NSP	600	600	600000	607999	8000	15	600	614	X0-9	MINN
Municipal Data from Xcel Energy	MUNI		605							5(0-9)	MINN
MMPA Municipal Data from Xcel Energy	MMPA		606							6(0-9)	MINN
CMMPA Municipal Data from Xcel Energy	CMMPA		607							7(0-9)	MINN
Minnesota Power & Light	MP	608	608	608000	609999	2000	8	615	622	P0-9	MINN
	FUTURE	610-612	610-612	610000	612999	3000	5	623	627		
Southern Minnesota Municipal Power Association	SMMPA	613	613	613000	614999	2000	8	628	635	A0-9	MINN
Great River Energy	GRE	615	615	615000	619999	5000	12	636	647	G0-9	MINN
Otter Tail Power Company	OTP	620	620	620000	624999	5000	8	648	655	T0-9	MINN
Rochester Public Utilities	RPU		625	625000	625999	1000	2	656	657	U0-9	MINN
Minnkota Power Cooperative, Inc.	MPC		657	657000	657999	1000	4	1620	1623	C0-9	DAKS
	FUTURE	626	626	626000	626999	1000	3	658	660		
Alliant Energy West	ALTW	627	627	627000	632999	6000	15	661	675	J0-9	IOWA
Muscatine Power & Water	MPW	633	633	633000	634999	2000	2	676	677	Q0-9	IOWA
MidAmerican Energy	MEC	635	635	635000	639999	5000	8	678	685	M0-9	IOWA
(MEC Future)	FUTURE		636-637							2(0-9)	IOWA
MEC Municipal Data From MEC (AMES,CFU, etc.)	MUNI		639							4(0-9)	IOWA
Nebraska Public Power District	NPPD	640	640	640000	644999	5000	5	686	690	N0-9	NEB
Municipal Energy Agency of Nebraska (NPPD)	MEAN		641							E0-9	NEB
Grand Island (NPPD)	GRIS		642							F0-9	NEB
Omaha Public Power District	OPPD	645	645	645000	649999	5000	5	691	695	O0-9	NEB
Lincoln Electric System, NE	LES	650	650	650000	650999	1000	2	696	697	L0-9	NEB
	FUTURE	651	651	651000	651999	1000	2	698	699		
Western Area Power Administration	WAPA	652	652	652000	654999	3000	16	1600	1615	W0-9	DAKS
Corn Belt Power Cooperative	CBPC		656	656000	656999	1000	1	1616	1616	1(0-9)	IOWA
NIMECA Municipal Data From CBPC	NIMECA		655				1	1617	1617	3(0-9)	IOWA
Missouri River Energy Services	MRES		658	658000	658999	1000	4	1624	1627	R0-9	DAKS
Basin Electric Power Cooperative	BEPC		659	659000	659999	1000	6	1628	1633	B[0-9BW]*1	DAKS
Northwestern Public Service	NWPS		660	660000	660999	1000	2	1634	1635	Z0-9	DAKS
Heartland Consumer Power District	HCPD		662	662000	662999	1000	1	1641	1641	V0-9	DAKS
Montana-Dakota Utilities Co.	MDU	661	661	661000	661999	1000	5	1636	1640	Y0-9	DAKS

	FUTURE	663-666	663-666	663000	666999	4000	4	1642	1645		
Manitoba Hydro	MHEB	667	667	667000	671999	5000	8	1646	1653	H0-9	CANADA
Saskatchewan Power Co.	SPC	672	672	672000	675999	4000	8	1654	1661	S0-9	CANADA
	FUTURE	676-679	676-679	676000	679999	4000	4	1662	1665		
Dairyland Power Cooperative	DPC	680	680	680000	681999	2000	10	1666	1675	D0-9	WIS
Wisconsin Public Power Inc.	WPPI		682	682000	682999	1000				I0-9	WIS
	FUTURE	683-690	683-690	683000	690999	8000	8	1676	1683		
American Transmission Company	ATC	691-699	691-699	691000	699999	9000	16	1684	1699	none	WUMS
Alliant Energy East	ALTE	694									WUMS
Wisconsin Public Service Corporation	WPS	696									WUMS
Consolidated Water Power Company	CWP										WUMS
Manitowoc Public Utilities	MPU										WUMS
Marshfield Electric and Water Company	MEWD										WUMS
Madison Gas and Electric Company	MGE	697									WUMS
Upper Peninsula Power Company	UPPC	698									WUMS
Totals						99,000	198				

*1 - BEPC/WAPA Co-supply load ID's 'BB'/'BW'

79000 170
21000 30

ATC Zone Name	Zone #
"WPL "	1684
"WPPI-WPL"	1685
"WPS "	1689
"WRWL-WPS"	1691
"CWP-WPS "	1692
"MEWD-WPS"	1693
"MPU-WPS "	1694
"WPPI-WPS"	1695
"MGE "	1697
"UPPC "	1698
"ESCANABA"	1688

Load ID Explanation

First Column - This character represents the company owning the load

Second Column - This character defines the load type (see below)

LOAD 0 (Seasonal Firm, can be scaled, not curtailed.)

LOAD 1 (Seasonal Interruptible, can be scaled, also curtailable)

LOAD 2 (Constant Firm, Not scaled, not curtailed.)

LOAD 3 (Constant Interruptible, not scaled, curtailable)

LOAD 4 (Conditional, Station Service Load)

LOAD 5 (Transmission Interruptible Load)

Explanation of load types:

All 0 (zero) type loads for ALL companies are identical load types, Seasonal Firm.

All 1 (one) type load for ALL companies are identical load types, Seasonal Interruptible.

Appendix B - Typical Parameters

These typical parameters shall be used only if all other means to obtain the data have been exhausted. . If you do use any of this data, please follow the data record “/” with the phrase “typical data.”

Thermal Generating Unit

GENROU

T'do=7.0	T''do=0.03	T'qo=-0.4	H=4.0	D=0.0	Xd=1.8
Xq=1.7	X'd=0.3	X''d=0.20	Xl=0.15	S(1.0)=0.1	S(1.2)=0.4

Data is in p.u. on machine MVA base

Hydraulic Generating Unit

GENSAL

T'do=5.0	T''do=0.03	T'qo=0.05	H=2.5	Xd=1.2	Xq=0.8
X'd=0.3	Xl=0.15	S(1.0)=0.1	S(1.2)=0.4		

Data is in p.u. on machine MVA base

Rotating Exciter (ac or dc)

IEEET1

Tr=0.015	Ka=20.0	Ta=0.05	Vrmax=3.0	Vrmin=-2.5	Ke=0.5	Te=0.20
Kf=0.1	Tf=1.5	switch=0	E1=1.5	Se(1.5)=0.2	E2=2.0	
Se(2.0)=0.5						

Static Exciter (moderate response time)

EXST1

Tr=0.015	Vimax=999.0	Vmin=-999.0	Tc=1.0	Tb=5.0	Ka=100.0
Ta=0.02	Vrmax=5.0	Vrmin=-4.5	Kc=0.1	Kf=0.0	Tf=1.0

Power System Stabilizers

It is recommended to not use typical data for stabilizers, even where it is known that the unit is equipped with a PSS.

Governors and Prime Movers

It is recommended not to model governors unless data is available.

Typical Overhead Transmission Line Parameters

Nominal Voltage	230 kV	345 kV	500 kV	765 kV	1,100 kV
R (Ω/km)	0.050	0.037	0.028	0.012	0.005
$x_L = \omega L$ (Ω/km)	0.488	0.367	0.325	0.329	0.292
$b_c = \omega C$ (us/km)	3.371	4.518	5.200	4.978	5.544
a (nepers/km)	0.000067	0.000066	0.000057	0.000025	0.000012
B (rad/km)	0.00128	0.00129	0.00130	0.00128	0.00127
Z_c (Ω)	380	285	250	257	230
SIL (MW)	140	420	1000	2280	5260
Charging MVA/km $= V^2_0 b_c$	0.18	0.54	1.30	2.92	6.71

Appendix C - Wind Turbine Generator (WTG) Models

C-1. Power Flow Model

C-1.1. Wind Generating Plant Topology

A wind farm contains many individual WTG's tied to a medium voltage collector system, and connected to the transmission system at a single location, referred to as the Point of Interconnection (POI). Figure C-1 shows the topology of a typical wind farm.

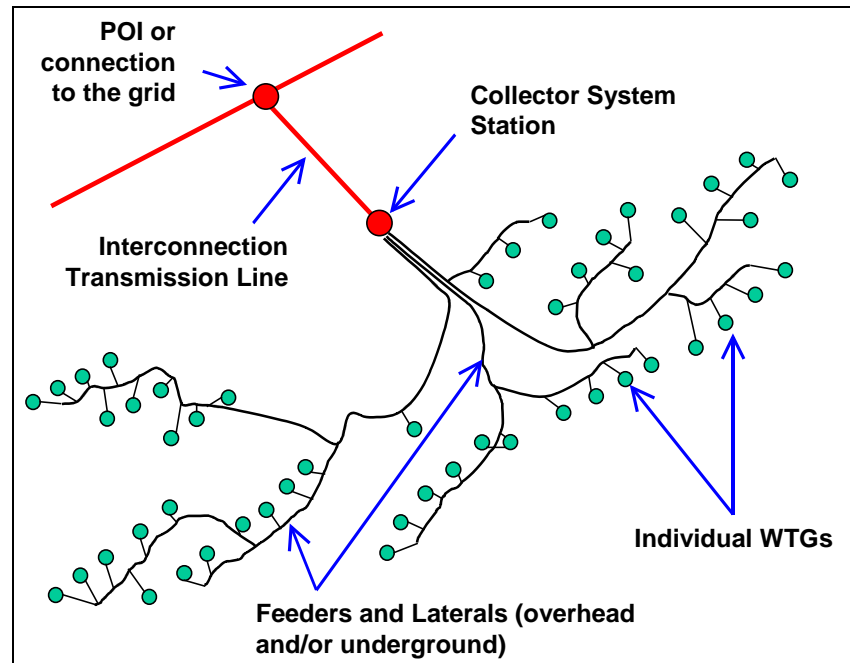

Figure C-1 – Wind Power Plant Topology [WECC]

Modern utility-scale WTGs have nameplate ratings ranging from 1 to 4 MW. Terminal voltage is typically around 600 Volts. A WTG step-up transformer connects each WTG to the collector system at 12 kV to 34.5 kV. The collector system consists of one or several feeders connected together at a collector system station. One or more transformers at the collector system station are used to achieve transmission system voltage. Unless the collector system station is adjacent to the POI, an interconnection transmission line will be needed. Reactive compensation in the form of mechanically switched capacitors and continuously variable devices such as SVCs or STATCOMs may be installed at the collector system station. Depending on the type of WTG, shunt reactive compensation at the WTG terminals may be installed for power factor correction. The amount and nature (static or dynamic) of reactive compensation is driven by interconnection requirements and collector system design considerations, including voltage profile and losses.

A detailed power flow model for a single machine equivalent of a wind generating plant generally includes some or all of the components shown in Figure C-2, below.

Modeled components include low voltage (LV), collector mid-voltage (MV), and high voltage (HV) facilities as follows:

- LV generator model reflecting net representation of a number of wind generators
- LV net model for capacitors where provided with the individual wind generators for power factor correction
- LV-MV generator step-up transformer (GSU) reflecting net representation of a number of wind generator step-up transformers
- MV equivalent branch to reflect the wind generating plant collector system
- MV static (capacitor) or dynamic (SVC, STATCOM, etc.) plant var support or var compensation device
- MV-HV sub-station transformer (SST) of the wind generating plant to the Point of Interconnection
- HV transmission line representation where required to connect to the Point of Interconnection

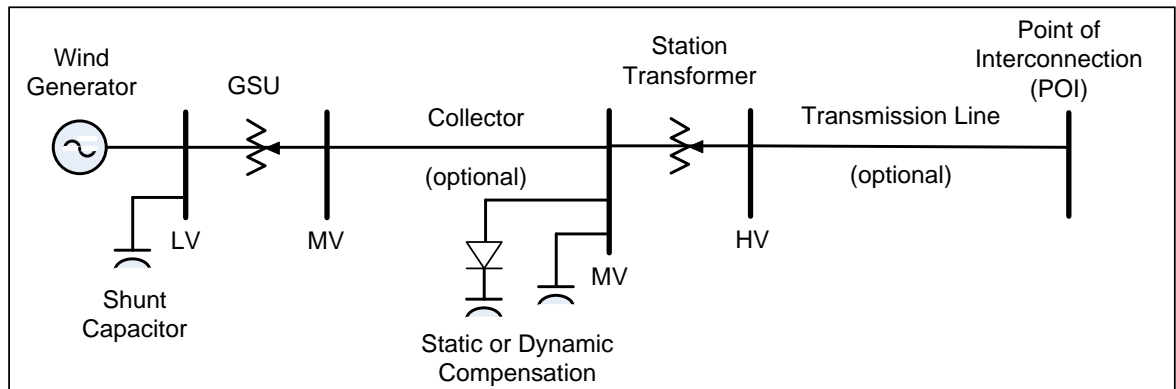

Figure C-2 – Single Machine Equivalent Power Flow Model

Not all the Figure C-2 components are applicable or critical for every wind generator representation. For example:

- The transmission line branch from the HV bus to the Point of Interconnection is only applicable if a new line section was added to connect to the grid.
- The equivalent collector circuit is required only when its impedance and/or charging is significant relative to that of the adjacent network components.

On the other hand, explicit modeling of the generator step-up transformer is required. This is necessary to produce a power flow model with accurate var flow and voltage profile and is of particular significance for the wind generator types for which the var output is very sensitive to voltage. Also, the main station transformer should always be modeled explicitly as it represents the majority of the impedance between the POI and the equivalent WTG.

C-1.2. Net Representation of Generating Units at a Wind Farm

An aggregate single-machine equivalent of a wind farm gives an indication of the terminal behavior of the “average” WTG in the farm. However, with proper parameters it should approximate wind farm characteristics at the POI. This model is adequate for regional studies where the requirement is to capture the wind farm impact on overall power system performance.

Individual wind generators can be aggregated into a net generator representation only when the units all have the same dynamic characteristics. This is necessary because the same model is used for both power flow and dynamic simulation.

For wind plant modeling, the fundamental goal is to aggregate like units as much as possible. The data submitter has the option to break the representation down further based on shared ownership and/or dispatch rights or collector station and feeder configurations, if considered appropriate.

C-1.3. MW Dispatch/Modeling

Several factors must be considered in setting wind generation schedules in our models:

- Capacity factor
- Coincidence of wind generation availability and peak load (or off-peak)
- Special conditions affecting wind generation availability
- Some wind generators do not operate at extreme temperature (high or low), as discussed below

The recommended wind generation dispatch (Pgen) levels in the MRO models are based on the quantitative analysis of historical wind generation data from the MRO region as shown in Table C-1 below.

NERC/MRO season	Peak	Off-Peak or Light Load
Spring	35%	35%
Summer	20%	35%
Fall	35%	35%
Winter	35%	35%

Table C-1 - Generation Dispatch Levels

Note: The wind generation dispatch levels should be set to suit the particular study being performed.

C-1.3.1 Modeling WTG at Reduced Generation Output

There are two choices on how to model the dispatch of a WTG at reduced generation output (e.g. 20% of nameplate rating):

- a) All machines dispatched at reduced output.
- b) Machines can run at 15-20% of rated output under reduced wind speed

- c) Reduced number of machines on-line, but each on-line machine at 100% rated output.

Option a) is the recommended approach since it is more plausible that reduced wind speed in a confined geographic area will equally affect the output of all wind turbines within the plant.

C-1.3.2 Considerations for Plants in Extreme Ambient Climate

Some regions within the MRO footprint experience extreme ambient conditions. This may impact the availability of their wind generators to operate during those extreme conditions.

C-1.4. MVAR Dispatch/Modeling

The PSS/E version 30 modeling concepts are explained below.

C-1.4.1 Generator Modeling – Mvar Limits and Voltage Control

The WTG will be modeled using the PSS/E Generator Data record. This section provides guidance on entering data for the reactive power capability range (Q_{max}/Q_{min}) for all four WTG generic types (see Section C-2.1).

WTG Type 1	$Q_{max} = Q_{min} =$ Mvar consumption (negative) by the equivalent/aggregate WTG, calculated at 100% rated (or applicable reduced) MW dispatch (P_{gen}).
WTG Type 2	Same as Type 1.
WTG Type 3	$Q_{max} =$ Mvar delivery (positive) by the equivalent/aggregate WTG based on its rated overexcited (+) power factor capability, calculated at the 100% rated (or applicable reduced) MW dispatch (P_{gen}). $Q_{min} =$ Mvar consumption (negative) by the equivalent/aggregate WTG based on rated underexcited power factor capability, calculated at the rated (or applicable reduced) MW dispatch (P_{gen}).
WTG Type 4	Same as Type 3.

Table C-2 - WTG Types

Per the above Table, WTG type 1 and 2 will have $Q_{gen} = Q_{max} = Q_{min}$ and any additional static and/or dynamic reactive compensation shall be explicitly modeled and dispatched to maintain the specified power factor of the wind generating plant. On the other hand, WTG type 3 and 4 will have Q_{gen} calculated to satisfy the generator’s voltage regulation setting and this Q_{gen} value shall be coordinated with any additional MVAR provided by plant-level reactive compensation (capacitor banks) to maintain the specified power factor or specified voltage of the wind generating plant.

Note that only Type 3 and Type 4 WTGs have the inherent capability of producing/supplying reactive power by operating at an overexcited power factor (similar to conventional generators). Since Type 1 and Type 2 WTGs are

essentially induction machines operating at an underexcited power factor, they will always consume/absorb reactive power. Therefore, the Type 1 and Type 2 WTGs will typically have Power Factor Correction (PFC) capacitors included within the WTG unit. The PFC capacitors within the WTG typically consist of several steps of switched capacitors which are controlled to enable constant power factor operation of the WTG from no load to full load output. If the reactive power compensation from the PFC capacitors is included within the reactive power capability limits (Q_{max}/Q_{min}) assigned to the WTG, the reactive power output (Q_{gen}) of the resulting generator model will not vary with the terminal voltage, which would be inconsistent with the actual behavior. Therefore, it is **recommended that the PFC capacitors included within the WTG should be modeled** explicitly by connecting a Switched Shunt PSS/E model at the generator bus.

Experience indicates that the WTGs are typically operated in a constant power factor mode, even though the overall wind generating plant may be operated in voltage control mode to regulate the transmission or collector bus voltage. Therefore, it is recommended that the WTG model use default values for the regulated voltage setpoint ($VS = 1.0$) and the regulated bus ($IREG=0$). For all wind generating plants having Type 1 and 2 WTGs, this modeling approach is expected to remain adequate. However, for future (or existing) wind generating plants using WTG Types 3 or 4 that may have the ability to be operated in voltage control mode, the modeling parameters VS and $IREG$ may be suitably modified to reflect the actual voltage regulation scheme implemented in the WTG.

Note: For Type 1 and 2 WTGs and for Type 3 and 4 WTGs operating in constant power factor mode, the Q_{max}/Q_{min} data for reduced MW dispatch can be obtained by proportionately reducing the $Mvar$ capability of the WTG --- that is, constant power factor operation is assumed for all WTG types. For Type 3 and 4 WTGs operating in voltage control mode the Q_{max}/Q_{min} data for reduced MW dispatch should be set according to the WTG capability curve.

For example, for the suggested MW dispatch at 35% of plant rating in seasonal spring/fall/winter peak models, the Q_{max}/Q_{min} values in the generator model for Type 1 and 2 WTGs and for Type 3 and 4 WTGs operating in constant power factor mode would also be 35% of the rated Q_{max}/Q_{min} capability (at 100% of plant rating).

C-1.4.2 Capacitor Bank Modeling

It is recommended that all capacitor banks within the wind generating plant be explicitly modeled. Typically, this will include the PFC capacitors available within the WTG as well as the mid-voltage (MV) capacitors connected to the collector system bus/feeder.

PFC Capacitors:

Since these capacitors are switched in/out to operate the WTG in constant power factor control mode, no voltage regulation parameters will be specified in the

switched shunt modeling data. Therefore, default values may be used for all model parameters except for MODSW and BINIT. The recommended parameter values are:

- MODSW = 0 for Fixed control mode
- BINIT = Mvar dispatch based on MW output of WTG and power factor correction setpoint.

The number of switched shunt steps and block sizes modeled (N_i , B_i) is up to the user's discretion.

Collector System (MV) Capacitors:

The modeling of these capacitors depends on whether the wind generating plant is required to operate in power factor control mode or voltage control mode. Generally, the interconnection agreements of many older wind generating plants (to which FERC Order 661-A does not apply) require them to maintain constant power factor at the Point of Interconnection (POI). For such facilities, the collector system capacitor modeling would be similar to that of the PFC capacitors. For those wind generating plants that are required to operate in accordance with a specified voltage schedule at the POI, the modeling considerations are discussed in the next section.

C-1.4.3 Wind Generating Plant – Volt-Var Control

In general, wind plants should have a strategy to control voltage at the Point of Interconnection (POI) [FERC Order 661-A]. In practice, this can be achieved in many different ways depending on the number and type of facilities provided.

The WTG may or may not have voltage control capability. Where able, there typically is a voltage control hierarchy providing effective control between the faster individual turbine controls and/or dynamic var support device controls (applicable to section 22), reacting to grid disturbances, and the slower plant supervisory control maintaining steady state voltage targets. This may be a complex scheme to provide overall wind generating plant voltage control --- involving the WTGs, supplementary capacitor banks in the collector system, supplementary dynamic var facilities (SVC, STATCOM, etc) in the collector system and wind generating plant step-up substation transformer equipped with on-load tap changers.

The following are a few suggested ways of modeling common voltage control schemes:

- If the wind generating plant uses switched shunt capacitors (at the collector station or in the collector feeder system) to regulate the transmission bus POI voltage within the range defined by VSWHI and VSWLO parameters, each shunt capacitor has to be modeled explicitly and switched in the “discrete” control mode (MODSW = 1) or continuous

control mode (since the wind farm is filled with a large number of small capacitors, this will almost make it look like a continuous control).

- Wind generating plants using dynamic var devices such as SVCs, STATCOMs, etc. in addition to (or in lieu of) switched shunt capacitors can be modeled on the bus to which the device is connected along with the designated regulated bus and voltage setpoint or regulation range.
- If the WTGs have reactive power capabilities (that is, Type 3 or 4 WTG), the bus number of the voltage regulated bus has to be specified in the generator model.

Depending on the voltage control facilities installed, one or more of the above schemes can be used. The data submitter should model the voltage regulation for each facility such that it accurately reflects the actual voltage control scheme used within the wind generating plant.

C-1.4.4 Rules of Thumb (credit WECC)

Based on the above observations, the following rules should be considered to model WTG reactive power capability and power factor correction capacitors:

- When Type 1 and Type 2 WTGs are used, reactive power consumption can be assumed to be $\frac{1}{2}$ of the power output. A capacitor should be shown at the WTG terminals to compensate power factor to unity at nominal voltage. For example, for a 100 MW wind power plant (WPP) at full output, both Q_{min} and Q_{max} would be set to -50 Mvar, and add a 50 Mvar shunt capacitor at the WTG terminals. Plant level reactive compensation may still be installed to meet interconnection requirements.
- If Type 3 or Type 4 WTGs are used, but they do not participate in steady-state voltage control, the equivalent generator should be set at a fixed power factor, typically unity. For example, Q_{min} and Q_{max} would be set to 0, at any active power level. No shunt capacitor would be needed at the WTG terminals. However, plant-level reactive compensation may still be installed to meet interconnection requirements.
- If Type 3 or Type 4 WTGs are used, and they actively participate in steady-state voltage control with the assistance of an external controller, the equivalent generator should have a reactive capability approximately equal to the WTG nominal range. The regulated bus is typically the POI, the collector system station, or some point in between. External reactive power compensation is not typically installed in these cases. For instance, if a 100 MW WPP employs WTGs with power factor range ± 0.95 at full output, Q_{min} should be set to -33 Mvar and Q_{max} should be set to +33 Mvar, assuming full WPP output. If a wind power plant is modeled at power output below rated, the reactive limits should be set according to the WTG capability curve.

C-2. Dynamic Model

There are challenges facing the industry in developing reliable, accurate and generic type dynamic models to represent these machines in regional stability studies. Much activity is underway in the industry to develop a complete library of acceptable wind generation dynamic models for broad distribution, such as the MRO models.

C-2.1. Wind Turbine Generator (WTG) – Technology Types

Despite the large variety of utility-scale WTGs in the market, each can be classified in one of four basic technology types. For the purpose of dynamic model development, these are classified as Types 1, 2, 3, and 4 based on topology and their interface with the grid. The four basic topologies are shown in Figure C-3.

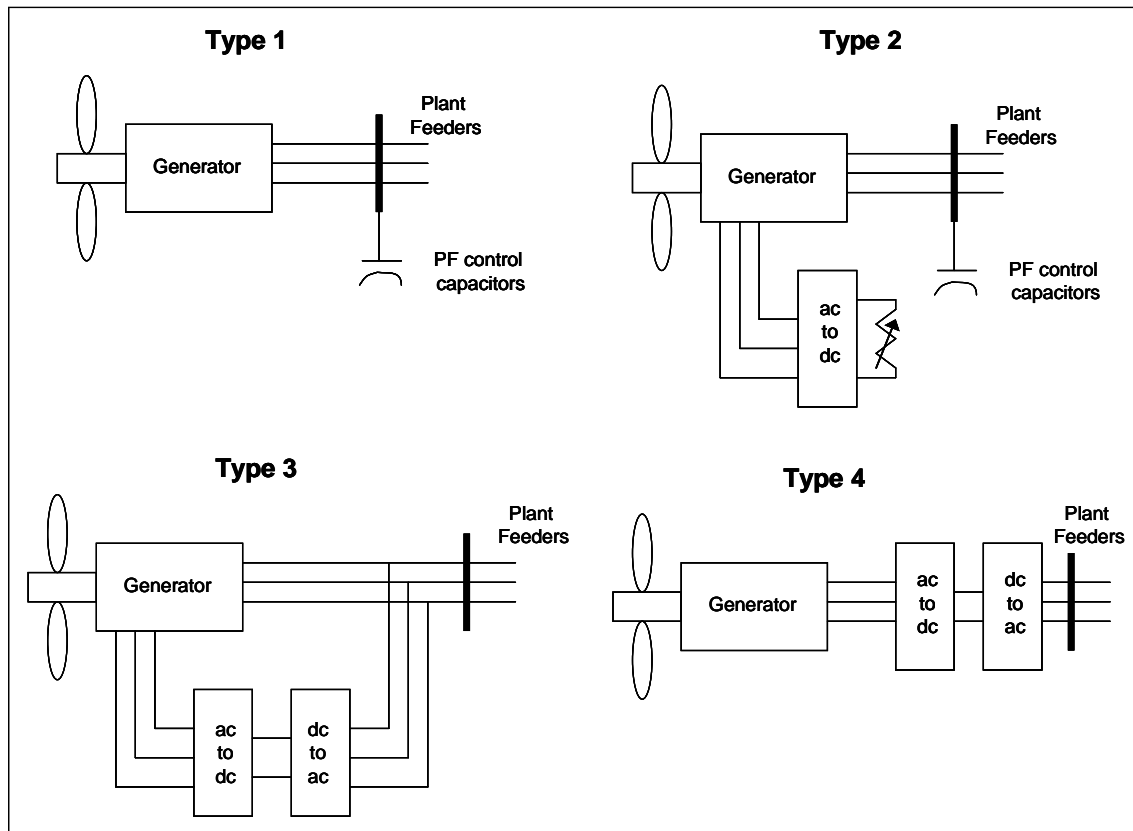

Figure C-3 - Four Basic Wind Turbine Topologies

Briefly, the four types of wind turbines can be described as follows:

- Type 1 - Fixed-speed, stall-regulated induction generators. They have no voltage control capability and only limited real power control capability.
- Type 2 - Induction generators with variable rotor resistance - these wind turbines are functionally between the fixed-speed and variable-speed

types, and utilize a pitch-regulated variable rotor resistance induction generator system. They have no voltage control capability and somewhat improved real power control capability.

Type 3 - Doubly-fed asynchronous generators with rotor-side converter (Doubly-fed induction generator (DFIG)). These machines are capable of voltage control and have high speed real and reactive power control capability.

Type 4 - Variable speed generators with full-power converter interface. These machines are capable of voltage control and have high speed real and reactive power control capability.

Detailed technical descriptions of each WTG type and power control technology employed is beyond the scope of this document, however extensive descriptions and functional diagrams are available in the information and workshops produced by efforts underway in the IEEE, Western Electricity Coordinating Council (WECC), Utility Wind Integration Group (UWIG) and International Council on Large Electric Systems (CIGRE).

C-2.2. Choosing the Right Dynamic Model

The types of PSS/E dynamic simulation models currently available for wind generation include:

- Older standard PSS/E induction generator models such as the CIMTR1 and CIMTR3,
- More detailed industry developed generic models, herein referred to as IEEE/WECC models, and
- Fully detailed manufacturer user-written models, either:
 - Available from PTI for broad distribution (MRO models) or
 - Available from PTI through a signed non-disclosure agreement with the turbine manufacturer, and not for broad distribution..

C-2.2.1 Standard Induction Generator

The following standard model types are available for dynamic simulation of induction wind generators using PSS/E. They are generic models and hence do not provide detailed representation of the machines. However, they were the best model available prior to 2007 for shared use in regional models.

- CIMTR1 - Single-cage or double-cage Induction generator with rotor flux transients
- CIMTR3 - Single-cage or double-cage Induction generator with rotor flux transients

Compared to CIMTR1, the CIMTR3 has an extra state and is more accurate for large frequency deviation, which is required for long-term simulation.

C-2.2.2 IEEE/WECC Generic Class Type

Recognizing that adequate dynamic models were not available for broad distribution, a large number of industry experts lead by the IEEE Dynamic Performance of Wind Power Generation Working Group (DPWPG) and the WECC Wind Generator Modeling Group (WGMG) have collaborated to fill the void. Members of the group include Siemens PTI, GE Energy (PSLF software) and a number of stakeholder groups including wind manufacturers and international wind organizations.

The intent was to provide models with improved representation over simple models like the CIMTR model discussed above. The IEEE/WECC generic models will have the capability to accept vendor specific WTG data parameters to accurately represent a specific generator installation.

A number of assumptions were made to allow simplification of the detailed manufacturer’s model into the generic models. A performance based modeling technique was used to produce a model that will provide an accurate response of a WTG to a grid disturbance but not to wind disturbances. Assuming constant wind speed is also feasible considering the smoothing effect on net wind power due to geographic diversity. Based on this assumption, pitch angle and aerodynamics used in the vendor detailed models can be disregarded. The drive train and pitch control is represented with a governor type model. This produced a simplified 2-mass model, which provides the fundamental response of the turbines without the high frequency component provided with the vendor detailed models.

PSS/E GENERIC MODEL STATUS		
Type 1	Directly connected conventional induction generator	Available beginning V31
Type 2	Directly connected wound rotor induction generator with variable rotor resistance	Available beginning V31
Type 3	Directly connected doubly-fed induction generator	Available beginning V29.5, V30.2, V30.3 and on
Type 4	A generator connected to the grid via the full size converter	Available beginning V31

Table C-3 - PSS/E Generic Model Availability and Status

As shown in the preceding table, all generic models are available beginning PSS/E V31. Application of generic wind model Type 3 in PSS/E V29 or 30 (the only type available) would lose several features as machines can only be treated specifically as wind turbine models beginning PSS/E V31.

However, additional work is underway to complete the library of turbine specific data parameter sets necessary to apply the preceding models for specific

applications. Please refer to the PTI site for information on currently available data sets.

C-2.2.3 Detailed User-written Model

The manufacturer models, which are detailed user-written models, are the most accurate models. They are most suited for local Interconnection Assessment studies.

Based on the vintage of the detailed models they may or may not be self-initializing for dynamics. With the newer versions most are treated like conventional machines and initialize correctly in dynamics based on their dispatch in power flow. Older versions required different dynamics DYRE data based on power flow power flow dispatch level. PTI's web site indicates whether models are self-initializing.

They fall into two categories:

- a. Available from PTI without the need for a non-disclosure agreement with the manufacturer. They may be written by PTI or the manufacturer. They are suitable for broad distribution like the MRO models. Only **self-initializing models** must be used in MRO models to avoid dynamics initialization issues.
- b. Available from PTI through a signed non-disclosure agreement with the turbine manufacturer due to confidentiality issues. They are therefore not suitable for broad distribution but only for local Interconnection Assessment studies.